

**Commodore**

**1407**

**MONOCROME MONITOR**

**Service Manual**

**8.91**

**PN-400412-01**

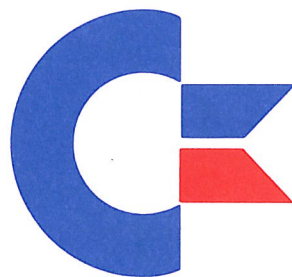

**Commodore**

*Produced By:*

**Commodore International Spare Parts GmbH  
Braunschweig, West Germany**

***SERVICE MANUAL***

**1407**

**AUGUST, 1991**

**PN-400412-01**

***INTERNATIONAL EDITION***

**SERVICE POLICY AND PART NUMBER INFORMATION MAY VARY ACCORDING TO COUNTRY. SOME PARTS MAY NOT BE AVAILABLE IN ALL COUNTRIES.**

**Commodore Business Machines, Inc.**

1200 Wilson Drive, West Chester, Pennsylvania 19380 U.S.A.

Commodore makes no express or implied warranties with regard to the information contained herein. The information is made available solely on an as is basis, and the entire risk as to completeness, reliability, and accuracy is with the user. Commodore shall not be liable for any damages in connection with the use of the information contained herein. The listing of any available replacement part herein does not constitute in any case a recommendation, warranty or guaranty as to quality or suitability of such replacement part. Reproduction or use without express permission, of editorial or pictorial content, in any matter is prohibited.

This manual contains copyrighted and proprietary information. No part of this publication may be reproduced, stored in a retrieval system, or transmitted in any form or by any means, electronic, mechanical, photocopying, recording or otherwise, without the prior written permission of Commodore Electronics Limited.

Copyright © 1991 by Commodore Electronics Limited.  
All rights reserved. Printed in U.S.A.

## TABLE OF CONTENTS

### **SECTION 1 — SPECIFICATIONS**

1.1 SPECIFICATIONS.....	1-1
-------------------------	-----

### **SECTION 3 — TROUBLESHOOTING**

3.1 ADJUSTMENT PROCEDURES.....	3-1
3.2 SCHEMATIC AND WAVEFORM NOTES.....	3-1
3.3 NAPCEC SAFETY GUIDELINES FOR THE PROFESSIONAL SERVICE TECHNICIAN.....	3-2
3.4 WARNING .....	3-4
3.5 SAFETY PRECAUTIONS.....	3-4
3.6 GENERAL.....	3-4

### **SECTION 4 — PARTS**

CRT SOCKET P.C. BOARD.....	4-1
BOARD LAYOUT.....	4-2
PCB CABINET PARTS LIST (110V and 220V VERSIONS).....	4-3
PCB COMPONENTS PARTS LIST (110V VERSION).....	4-4
PCB COMPONENTS PARTS LIST (220V VERSION).....	4-6

### **SECTION 5 — SCHEMATICS**

WIRING DIAGRAM.....	5-1
WAVEFORM PHOTOS (110V VERSION).....	5-2
SCHEMATIC DIAGRAM (110V VERSION).....	5-2
SCHEMATIC DIAGRAM (220V VERSION).....	5-3

<b>ACKNOWLEDGEMENTS.....</b>	<b>A-1</b>
------------------------------	------------

**SECTION 1**  
**SPECIFICATIONS**

1.1 SPECIFICATIONS (Continued)

**CUSTOMER ADJUSTMENT**

*Connection*

Connect the monitor to the computer. The monitor is connected with a 15-pin D-shell connector.

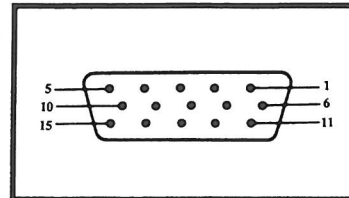
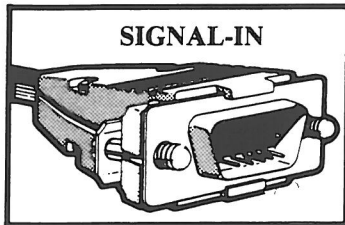

SIGNAL IN (15-pin D-shell connector)

*Adjustment and controls*

- a. Power on/off switch SK1 (LED lights up)

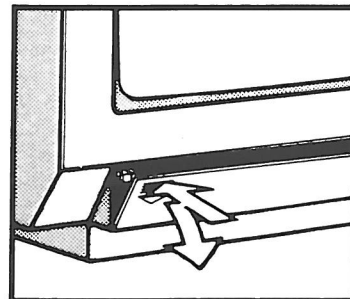
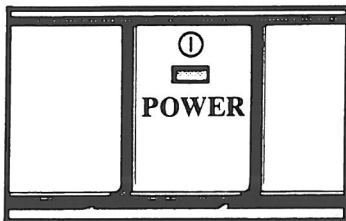

- b. Contrast can be adjusted with control (R312).
- c. Brightness can be adjusted with control (R540).

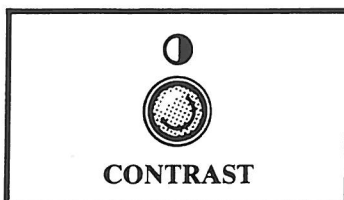

*Movable support*

You can tilt the monitor into a convenient position with regard to the computer by using the movable support.

*Pedestal*

The pedestal enables you to place the monitor into a convenient position by tilting and/or turning the monitor. For mounting, see diagrams on next page.

*Note*

The monitor has a self-test facility where the screen lights up when the cable is disconnected.

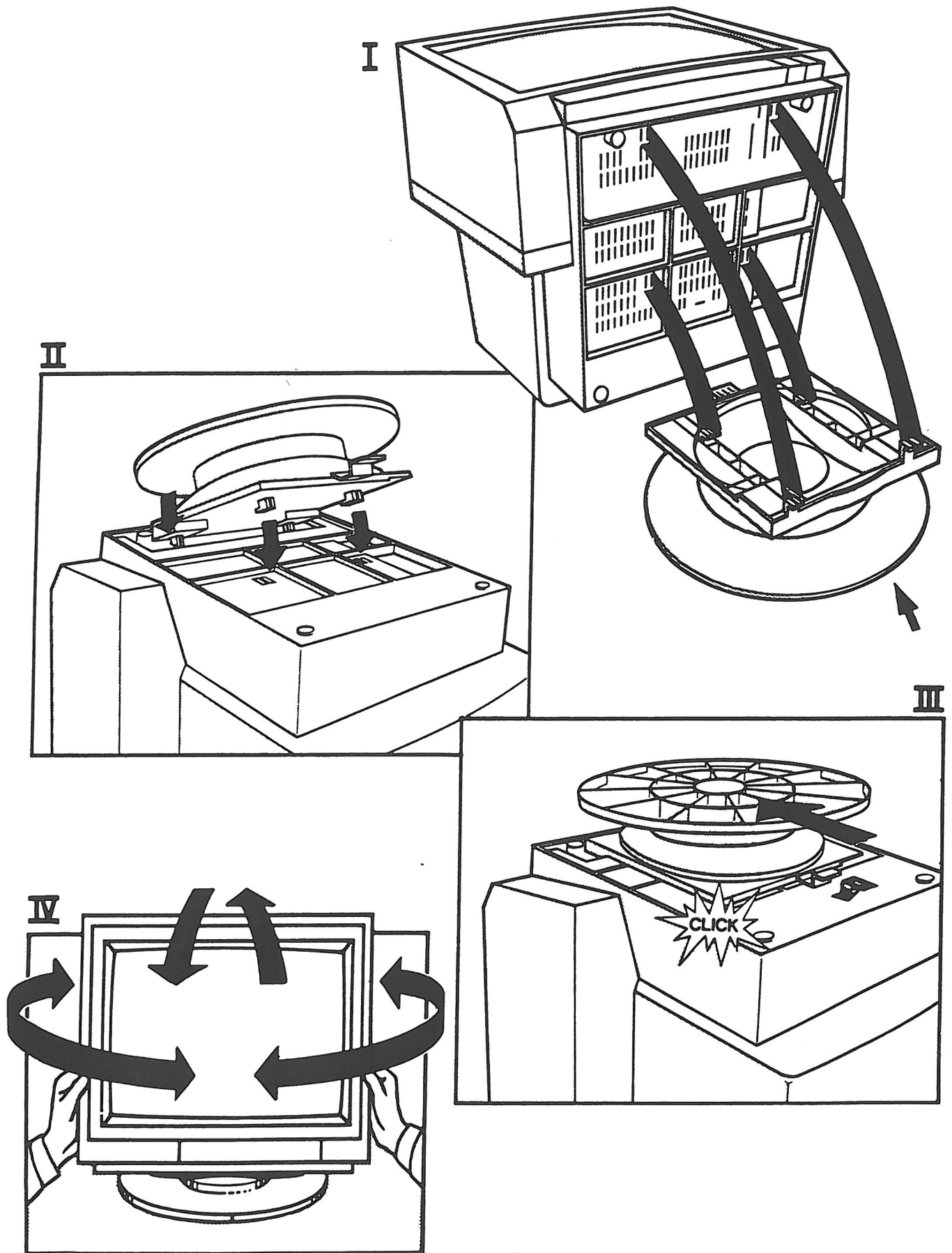

MOUNTING DIAGRAMS

**SECTION 3**  
**TROUBLESHOOTING**

### 3.1 ADJUSTMENT PROCEDURES

#### **ADJUSTMENT NOTES**

Use an isolation transformer when servicing this unit. All adjustments were performed with the line voltage maintained at 120Vac, 60Hz. This unit should be allowed to warm up for at least 30 minutes prior to making any adjustments. All voltages measured with respect to ground. Signal source is a Network Technologies Incorporated Montest-A5D3 generator. Except where noted otherwise, the generator was set to 31.5kHz/480 line mode, composite sync, intensity on and green on.

#### **SUPPLY VOLTAGE ADJUSTMENT**

Inject a bar pattern signal and connect a voltmeter across C135. Adjust R106 for a reading of 45Vdc.

#### **HORIZONTAL SYNCHRONIZATION ADJUSTMENT**

Inject a crosshatch pattern signal and connect a jumper from C502 to ground. Adjust R509 to its mechanical center. Adjust R510 for proper horizontal synchronization. Remove the jumper.

#### **VERTICAL SYNCHRONIZATION**

Inject a crosshatch pattern signal. Adjust R422 for proper vertical synchronization.

#### **SUB BRIGHTNESS ADJUSTMENT**

Inject a raster signal. Adjust the brightness control (R540) to maximum and the contrast control (R312) to minimum. Adjust R541 so that the flyback lines are no longer visible.

### 3.2 SCHEMATIC AND WAVEFORM NOTES

#### **UNLESS OTHERWISE SPECIFIED**

For voltage, wattage or tolerance ratings of components, refer to the electrical replacement parts list.

\*Indicates component is raised above the P.C. board. Signal source for all voltages and waveform photos:

Network Technologies Incorporated Montest-A5D3 signal generator (or equivalent).

Except where otherwise noted, the generator was set to display a bar pattern in 31.5kHz/480 line resolution mode. Voltages within brackets were taken with no signal input and are only shown where an appreciable change was noted between voltages taken with signal and without signal. Line voltage was maintained at 120Vac, 60Hz via an isolation transformer. The contrast control was set for a reading of 9.5Vdc at the wiper of R312 and the brightness control was set for a reading of -10Vdc at the wiper of R540.

#### **VERTICAL LINEARITY ADJUSTMENT**

Inject a crosshatch pattern signal. Adjust R430 for proper linearity at both the top and bottom of the screen.

#### **HORIZONTAL AMPLITUDE**

Inject a crosshatch pattern signal. Adjust L531 for proper horizontal width.

#### **HORIZONTAL POSITION**

Inject a crosshatch pattern signal. Adjust R509 to properly center the display.

#### **VERTICAL AMPLITUDE**

Inject a crosshatch pattern signal. Adjust R425 for proper vertical height. Inject a crosshatch pattern signal in 400 line resolution mode. Adjust R409 for proper vertical height. Inject a crosshatch pattern signal in 350 line resolution mode. Adjust R410 for proper vertical height.

#### **FOCUS ADJUSTMENT**

Inject a crosshatch pattern signal. Adjust R715 for proper focus.

All voltages and waveforms should be measured with respect to a ground as close as possible to the point to be measured. Voltages are positive dc with respect to ground (either signal ground  $\perp$  or hot ground  $\downarrow$ ) and may vary due to normal production tolerances. Voltage sources are also nominal, with the exception of the +45Vdc source, which is set at the factory to be within  $\pm 1$ Vdc. Numbers 1 through 28 within circles correspond to waveform photos. Sweep time/CM settings are shown just below the photos and were in the calibrated position. Horizontal positioning of the waveforms was adjusted for maximum clarity.



### 3.3 NAPCEC SAFETY GUIDELINES (Continued)

#### **X-RADIATION (Continued)**

nected HV meter to the shop test fixture is advisable. The CRT types used in these new sets should never be replaced with any other types, as this may result in excessive X-radiation.

It is essential to use the specified picture tube to avoid a possible X-radiation problem.

Most TV receivers contain some type of emergency "Hold Down" circuit to prevent HV from rising to excessive levels in the presence of a failure mode. These various circuits should be understood by all technicians servicing them, especially since many hold down circuits are inoperative as long as the receiver performs normally.

#### **LEAKAGE CURRENT COLD CHECK**

Unplug the ac line cord and connect a jumper between the two prongs of the plug.

Turn on the power switch.

Measure the resistance value between the jumpered ac plug and all exposed cabinet parts of the receiver, such as screw heads, antenna and control shafts. When the exposed metallic part has a return path to the chassis, the reading should be between 1 megohm and 5.2 megohms. When the exposed metal does not have a return path to the chassis, the reading must be infinity. Remove the jumper from the ac line cord.

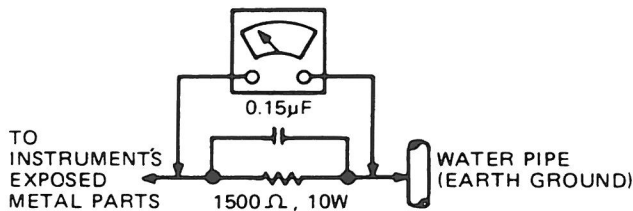

#### **LEAKAGE CURRENT HOT CHECK**

Do not use an isolation transformer for this test. Plug the completely re-assembled receiver directly into the ac outlet.

Connect a 1.5k ohm, 10 watt resistor paralleled by a 0.15uF capacitor between each exposed metallic cabinet part and a good earth ground such as a water pipe, as shown above.

Use an ac voltmeter with at least 5000 ohms/volt sensitivity to measure the potential across the resistor.

The potential at any point should not exceed 0.75 volts. A leakage current tester may be used to make this test; leakage current must not exceed 0.5 milliamps. If a measurement is outside the limits specified, there is a possibility of shock hazard. The receiver should be repaired and rechecked before returning it to the customer.

Repeat the above procedure with the ac plug reversed. (Note: An ac adapter is necessary when a polarized plug is used. Do not defeat the polarizing feature of the plug.)

#### **PICTURE TUBE REPLACEMENT**

The primary source of X-radiation in this television receiver is the picture tube. The picture tube utilized in this chassis is specially constructed to limit X-radiation emissions. For continued X-radiation protection, the replacement tube must be the same type as the original, including suffix letter, or an N.A.P. Consumer Electronics Corp. (NAPCEC) approved type.

#### **PARTS REPLACEMENT**

Many electrical and mechanical parts in NAPCEC television sets have special safety-related characteristics. These characteristics are often not evident from visual inspection nor can the protection afforded by them necessarily be obtained by using replacement components rated for higher voltage, wattage, etc. The use of a substitute part which does not have the same safety characteristics as the NAPCEC recommended replacement part shown in this service manual may create shock, fire or other hazards.

**SECTION 4**

**PARTS**

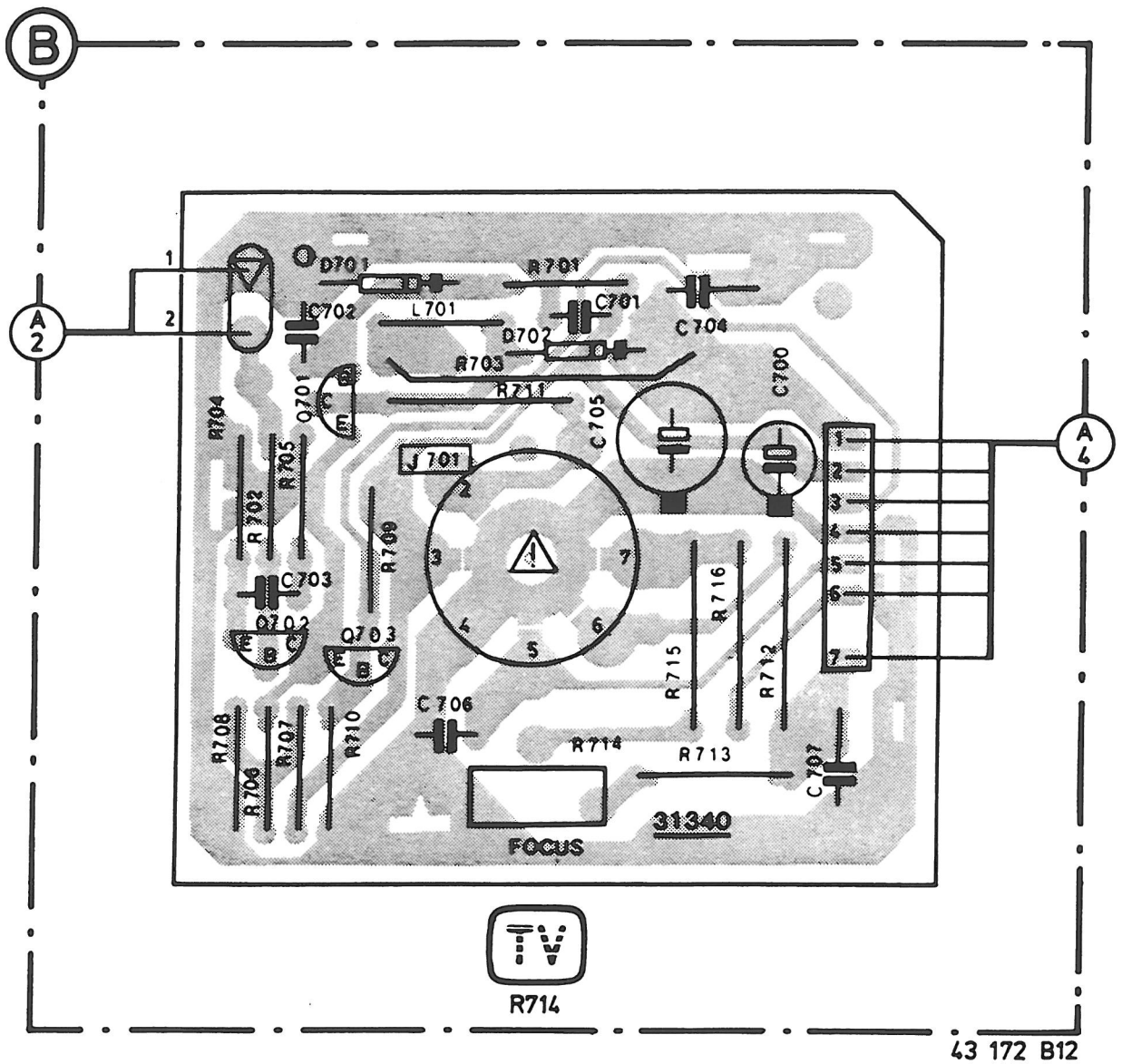

**CRT SOCKET P.C. BOARD**  
 (VIEWED FROM THE COMPONENT SIDE.)

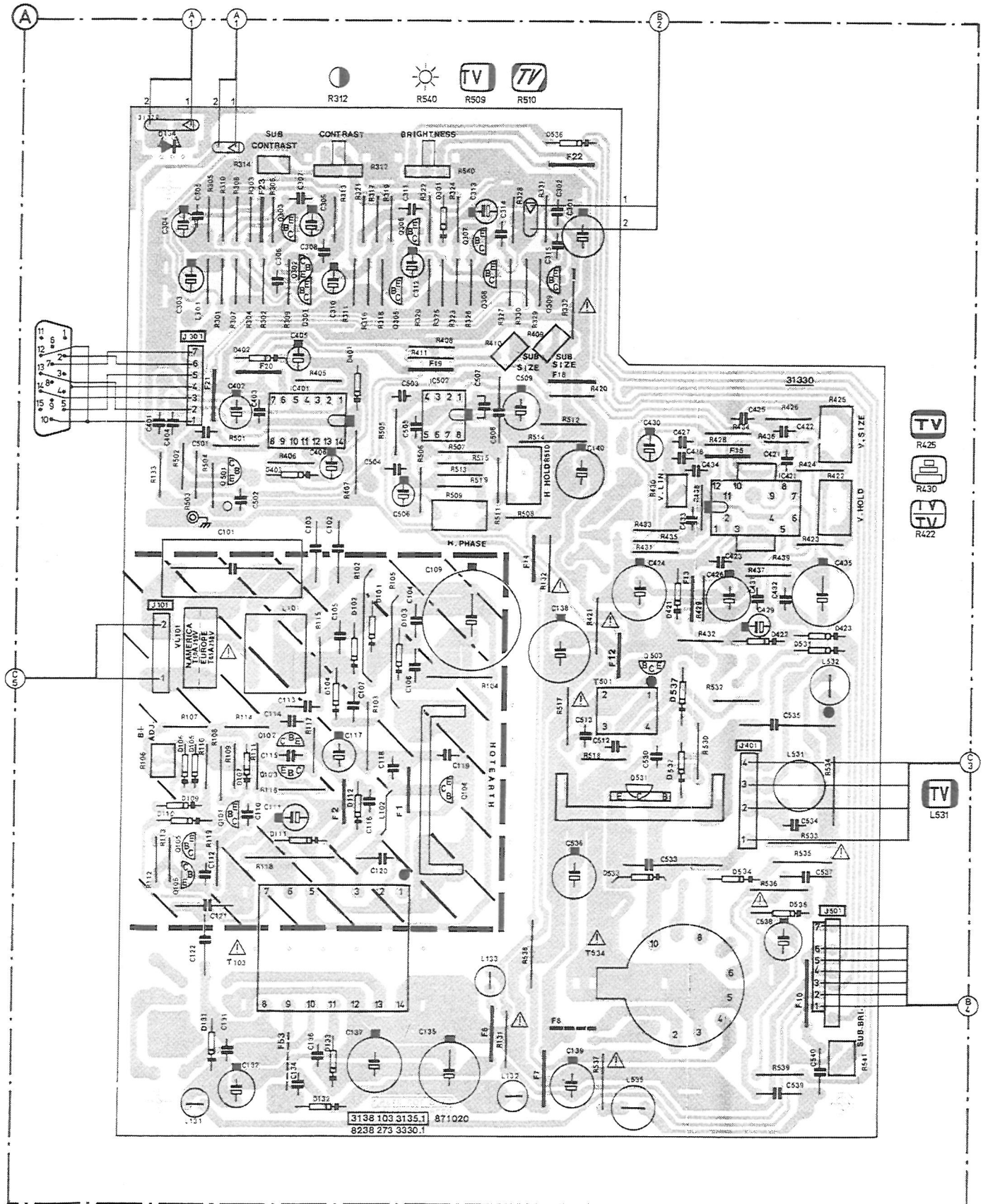

BOARD LAYOUT

**Commodore International Spare Parts List**  
**PCB CABINET PARTS (110V and 220V VERSIONS)**  
**PCB Assembly #1407**

Commodore part numbers are provided for reference only and do not indicate the availability of spare parts from Commodore. Industry standard parts (Resistors, Capacitors, Connectors) should be secured locally. Part number information may vary according to country, some parts may not be available in all countries.

602316-001	CABINET, FRONT	602316-006	KNOBS, 2"
602316-002	CABINET, REAR	602316-007	BUTTON, POWER ON/OFF PUSH-
602316-003	PAD, FRONT	602316-008	FOOT
602316-004	PAD, REAR	602316-009	PEDESTAL ASSY
602316-005	COVER, ADJ PANEL	602316-010	SCREW, CABINET REAR, (QTY = 4)

## Commodore International Spare Parts List PCB Components (110V VERSION) PCB Assembly #1407

Commodore part numbers are provided for reference only and do not indicate the availability of spare parts from Commodore. Industry standard parts (Resistors, Capacitors, Connectors) should be secured locally. Part number information may vary according to country, some parts may not be available in all countries.

602316-011	CAP 0.1UF 125V LINE ACROSS	C101-S	602316-078	RES 10 OHM	R131-S,537-S
602316-012	CAP 0.001UF 20% 400V CERM	C102-S,C103-S,C122-S	602316-079	RES 4.7 OHM	R132-S,421-S,517-S
602316-013	CAP 0.0022UF 10% 1KV CERM	C104,105,106,107	602316-080	RES 75 OHM	R301,306,702
602316-014	CAP 100UF 200V ELEC	C109	602316-081	RES 20K OHM	R302
602316-015	CAP 470PF 10% 100V CERM	C110	602316-082	RES 2.7K OHM	R303,318
602316-016	CAP 2.2UF 50V ELEC	C111	602316-083	RES 1.6K OHM	R304
602316-017	CAP 0.022UF 20% 50V CERM	C112,302,305,308,315, 403,423,431,507,701, 702	602316-084	RES 5.1K OHM	R305,436
602316-018	CAP 0.1UF 10% 63V POLY	C113,306,427,428,432, 503,C706	602316-085	RES 390 OHM	R112,307,309,310,322
602316-019	CAP 680PF 10% 50V CERM	C114	602316-086	RES 150 OHM	R308
602316-020	CAP 220PF 10% 50V CERM	C115,501	602316-087	RES 1.5K OHM	R311,708
602316-021	CAP 0.22UF 10% 63V POLY	C116	602316-088	RES 4.0K OHM POTENTIOMETER	R312
602316-022	CAP 100UF 25V ELEC	C117	602316-089	RES 5.6K OHM	R313
602316-023	CAP 180PF 10% 500V CERM	C118	602316-090	RES 6.8K OHM	R316
602316-024	CAP 0.0015UF 10% 50V CERM	C119	602316-091	RES 2.2K OHM	R317,319
602316-025	CAP 0.0047UF 10% 630V POLY	C120	602316-092	RES 300 OHM	R320
602316-026	CAP 560PF 10% 500V CERM	C131,134,136	602316-093	RES 150 OHM	R321,518
602316-027	CAP 22UF 100V ELEC	C132,536,705	602316-094	RES 620 OHM	R324
602316-028	CAP 220UF 63V ELEC	C135	602316-095	RES 100K OHM	R325,507
602316-029	CAP 1000UF 25V ELEC	C137	602316-096	RES 270K OHM	R326,539
602316-030	CAP 470UF 25V ELEC	C138	602316-097	RES 1K OHM	R327,420,503,519
602316-031	CAP 330UF 16V ELEC	C139	602316-098	RES 270 OHM	R328
602316-032	CAP 470UF 16V ELEC	C140,301	602316-099	RES 330 OHM	R330,405
602316-033	CAP 47UF 16V ELEC	C303,304,309,310	602316-100	RES 750 OHM	R331
602316-034	CAP 15PF 5% 50V CERM	C307	602316-101	RES 5.6 OHM	R332-S
602316-035	CAP 10PF 20% 50V CERM	C311	602316-102	RES 180 OHM	R406
602316-036	CAP 2.2UF 50V ELEC	C312	602316-103	RES 270 OHM	R407,514
602316-037	CAP 22UF 16V ELEC	C313,405,700	602316-104	RES 120K OHM	R408
602316-038	CAP 0.047UF 20% 100V POLY	C314	602316-105	RES 220K OHM POTENTIOMETER	R409,410
602316-039	CAP 100PF 5% CERM	C401,404	602316-106	RES 12 OHM	R411,506
602316-040	CAP 100UF 16V ELEC	C402,509	602316-107	RES 200K OHM POTENTIOMETER	R422,425
602316-041	CAP 4.7UF 25V ELEC	C406	602316-108	RES 56K OHM	R423
602316-042	CAP 0.01UF 100V POLY	C421,502,504,513	602316-109	RES 180K OHM	R424,426,713
602316-043	CAP 0.15UF 5% 63V POLY	C422	602316-110	RES 560K OHM	R428
602316-044	CAP 1000UF 16V ELEC	C424	602316-111	RES 820 OHM	R113,429,512
602316-045	CAP 0.0018UF 10% 50V CERM	C425	602316-112	RES 47K OHM POTENTIOMETER	R430
602316-046	CAP 100UF 35V ELEC	C426	602316-113	RES 30K OHM	R431
602316-047	CAP 10UF 50V ELEC	C429	602316-114	RES 10K OHM	R323,432,501
602316-048	CAP 33UF 16V ELEC	C430	602316-115	RES 27K OHM	R433,707
602316-049	CAP 22PF 5% 50V CERM	C433	602316-116	RES 5.6K OHM	R434,435
602316-050	CAP 680UF 25V ELEC	C435	602316-117	RES 2.2 OHM	R437
602316-051	CAP 0.0047UF 10% 50V CERM	C505	602316-118	RES 220K OHM	R438
602316-052	CAP 1UF 50V ELEC	C506	602316-119	RES 1.2 OHM	R439
602316-053	CAP 0.0027UF 5% 63V	C508	602316-120	RES 5.6K OHM	R502-S
602316-054	CAP 0.47UF 20% 63V POLY	C512,530	602316-121	RES 15K OHM	R329,505,508,511,710
602316-055	CAP 0.0075UF 5% 630V POLY	C533	602316-122	RES 5K OHM POTENTIOMETER	R509,510
602316-056	CAP 0.0033UF 10% 100V CERM	C434,534	602316-123	RES 1.8K OHM	R513
602316-057	CAP 0.75UF 10% 100V POLY	C535	602316-124	RES 2.4K OHM	R515
602316-058	CAP 0.01UF 20% 1KV CERM	C537	602316-125	RES 1 OHM	R530
602316-059	CAP 10UF 100V ELEC	C538	602316-126	RES 2K OHM	R532
602316-060	CAP 0.0027UF 400V POLY	C539	602316-127	RES 120 OHM 0.5W	R533,711
602316-061	CAP 0.0039UF 10% 400V POLY	C540	602316-128	RES 270 OHM 0.5W	R534
602316-062	CAP 47PF 5% 50V CERM	C703	602316-129	RES 1K OHM	R535-S
602316-063	CAP 0.022UF 20% 100V POLY	C704	602316-130	RES 56 OHM	R536-S
602316-064	CAP 0.001UF 10% 1KV CERM	C707	602316-131	RES 36K OHM 0.5W	R538
602316-065	RES 2.2 OHM 2W	R102-S,R105-S	602316-132	RES 470K OHM POTENTIOMETER	R540
602316-066	RES 150K OHM 0.5W	R103,104	602316-133	RES 1M OHM POTENTIOMETER	R541
602316-067	RES 1K OHM POTENTIOMETER	R106	602316-134	RES 510 OHM	R701
602316-068	RES 3.9K OHM	R107	602316-135	RES 680 OHM 3W	R703-S
602316-069	RES 1.2K OHM 0.5W	R108,R133	602316-136	RES 62 OHM	R704
602316-070	RES 5.6K OHM	R109,114,313,434,435, R502-S	602316-137	RES 68 OHM	R705
602316-071	RES 18 OHM	R110	602316-138	RES 680 OHM	R706
602316-072	RES 8.2K OHM	R111	602316-139	RES 47K OHM	R709
602316-073	RES 680 OHM	R115	602316-140	RES 33K OHM 0.5W 10%	R712,716
602316-074	RES 4.7K OHM	R116,504	602316-141	RES 2M OHM POT, FOCUS	R714
602316-075	RES 10 OHM	R117	602316-142	RES 1.5M OHM 0.5W	R715
602316-076	RES 27 OHM 1W	R118	602316-143	LINE CHOKE	L101-S
602316-077	RES 220 OHM	R119	602316-144	COIL 2UH 10%	L102
			602316-145	TRANSFORMER, POWER SUPPLY	T103-S
			602316-146	COIL 100UH	L131,132,133
			602316-147	COIL 0.33UH	L301
			602316-148	TRANSFORMER, HORZ DRIVE	T501-S

\*S = SAFETY ITEM

## Commodore International Spare Parts List PCB Components (220V VERSION) PCB Assembly #1407

Commodore part numbers are provided for reference only and do not indicate the availability of spare parts from Commodore. Industry standard parts (Resistors, Capacitors, Connectors) should be secured locally. Part number information may vary according to country, some parts may not be available in all countries.

602317-001	RES 1K POTM	R106	602317-049	DIODE	BZX79/C6V8
602317-002	RES 220K OHM POTM	R409,410	602317-050	DIODE	BZX79/C24
602317-003	RES 5K POTM	R509,510	602317-051	IC	BC637
602317-004	RES 47K POTM	R430	602317-052	IC	BC337
602317-005	RES 1M POTM	R541	602317-053	IC	PH2369
602317-006	RES 470K POTM	R540	602317-054	DIODE	C0W11B
602317-007	RES 200K POTM	R422,425	602317-055	IC	BUT11AF
602317-008	RES 2M FOCUS POTM	R714	602317-056	IC	2SD1609
602317-009	RES 470 OHM POTM	R312	602317-057	IC	BC548C
602317-010	RES 4.7 OHM SAFETY	R132,421,517	602317-058	IC	BC558B
602317-011	RES 5.6 OHM SAFETY	R332	602317-059	IC	BC549C
602317-012	RES 10 OHM SAFETY	R131,537	602317-060	IC	BC548B
602317-013	RES 56 OHM SAFETY	R536	602317-061	DIODE	BZX79/C8V2
602317-014	RES 1K SAFETY	R535	602317-062	DIODE	BZX79/F5V1
602317-015	RES 4.7 OHM 2W	R102,105	602317-063	DIODE	BZX79/F15
602317-016	RES 120 OHM 1/2W	R533,711	602317-064	TRANSISTOR	1N4006GP
602317-017	RES 33K 1/2W	R712,716	602317-065	CRT, TUBE M32EBL2WD	
602317-018	RES 56 OHM 1W	R118	602317-066	TRANSFORMER LINE OUTPUT	T534
602317-019	RES 680 OHM 3W	R703	602317-067	TRANSFORMER POWER	T103
602317-020	CAP 470NF 250V	C101	602317-068	DEFLECTION UNIT 7BM7	U401
602317-021	CAP 7.5NF 630V	C534	602317-069	DEFLECTION UNIT BM79	U401
602317-022	CAP 750NF 100V	C535	602317-070	INDUCTOR COIL 2.2UH	L701
602317-023	CAP 10NF 1KV	C537	602317-071	INDUCTOR 100UH	L131,132,133
602317-024	CAP 100PF 1KF	C118	602317-072	INDUCTOR 0.33UH	L301
602317-025	CAP 1NF 1KV	C707	602317-073	TRANSFORMER DRIVE	T501
602317-026	CAP 150PF 500V	C121	602317-074	INDUCTOR COIL WIDTH	L531
602317-027	CAP 5.6NF 630V	C533	602317-075	INDUCTOR LINE CHOKE	L101
602317-028	CAP 1.5NF 1KV	C120	602317-076	INDUCTOR COIL	L535
602317-029	CAP 2.2NF 1KV	C104,105,106,107	602317-077	INDUCTOR LIN COIL	L532
602317-030	CAP 560PF 500V	C131,134,136	602317-078	IC	MC1391
602317-031	CAP 1NF 400V	C102,103,122	602317-079	IC	TDA1170N
602317-032	CAP 47UF 16V	C303,304,309,310	602317-080	INDUCTOR 2UH	L102
602317-033	CAP 33UF 16V	C430	602317-081	FUSE 0.5 AT250 V	VL101
602317-034	CAP 4.7UF 25V	C406	602317-082	SOCKET CRT	
602317-035	CAP 1UF 50V	C312,506	602317-083	CONN 4 POLE	
602317-036	CAP 10UF 50V	C429	602317-084	CONN 2 POLE	
602317-037	CAP 22UF 16V	C313,405,700	602317-085	CONN 7 POLE MICRO	
602317-038	CAP 22UF 100V	C132,536,705	602317-086	SWITCH POWER	
602317-039	CAP 1000UF 25V	C137	602317-087	SPRING FOR FUSE	
602317-040	CAP 47UF 400V	C109	602317-088	RES 270 OHM 1/2W	R534
602317-041	DIODE	BAW62	602317-089	CAP 2.7NF 63V	C508
602317-042	DIODE	BAV21	602317-090	CAP 22PF 50V	C433
602317-043	DIODE	RGP10G	602317-091	CAP 100UF 16V	C402,509
602317-044	DIODE	RGP10J	602317-092	CAP 10UF 100V	C538
602317-045	TRANSISTOR	1N4001	602317-093	CAP 100UF 35V	C426
602317-046	DIODE	RGP10M	602317-094	CAP 1000UF 16V	C424
602317-047	DIODE	RGP15K	602317-095	IC	74LS86N
602317-048	TRANSISTOR	1N4148	602317-096	CAP 100PF	C404,401

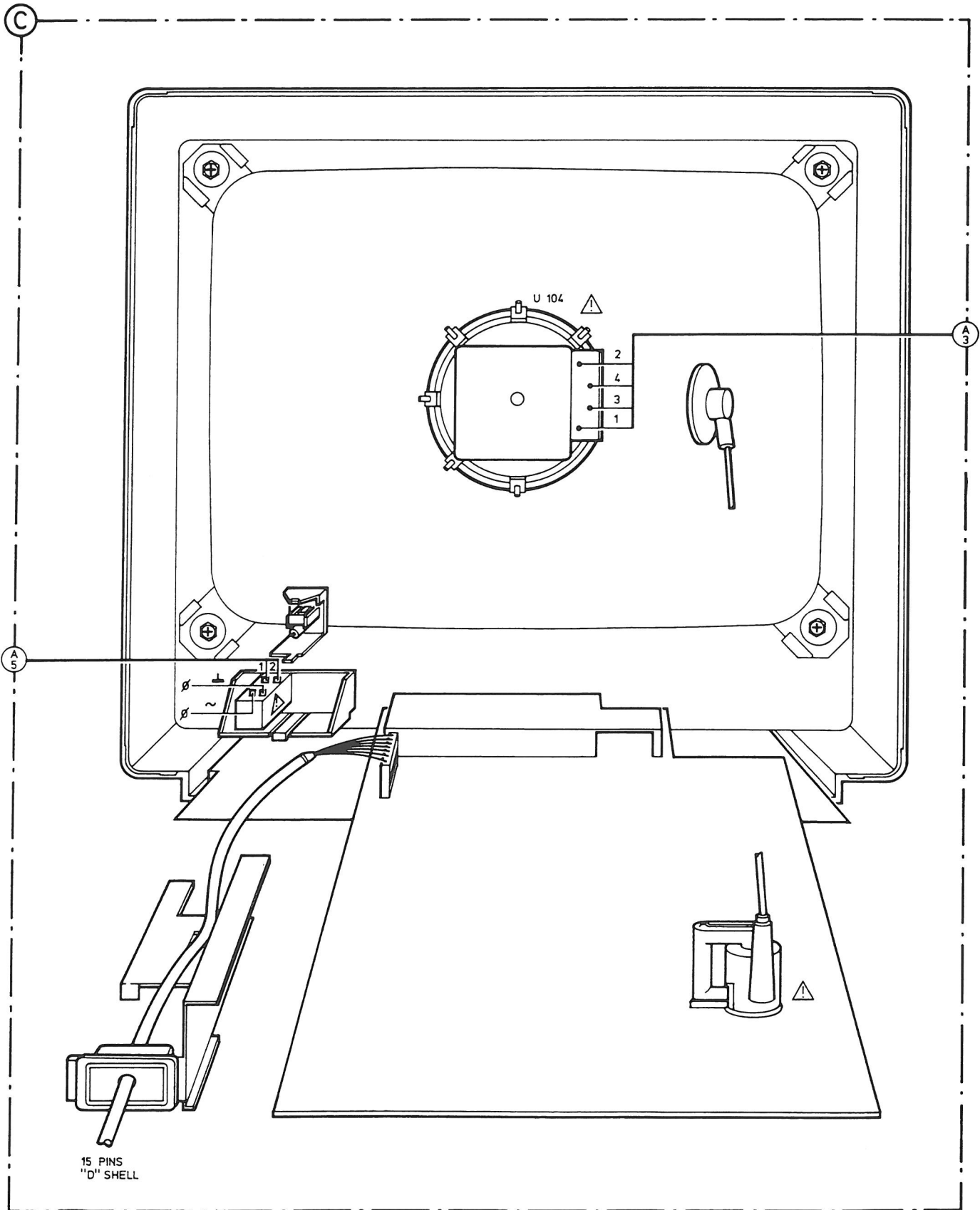

43 174 C12

WIRING DIAGRAM



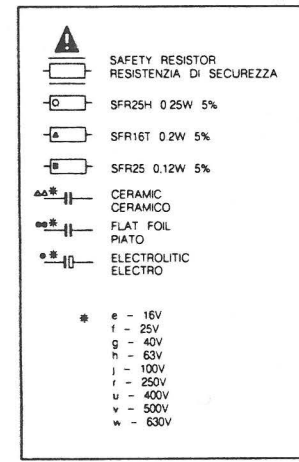

**POWER SUPPLY**

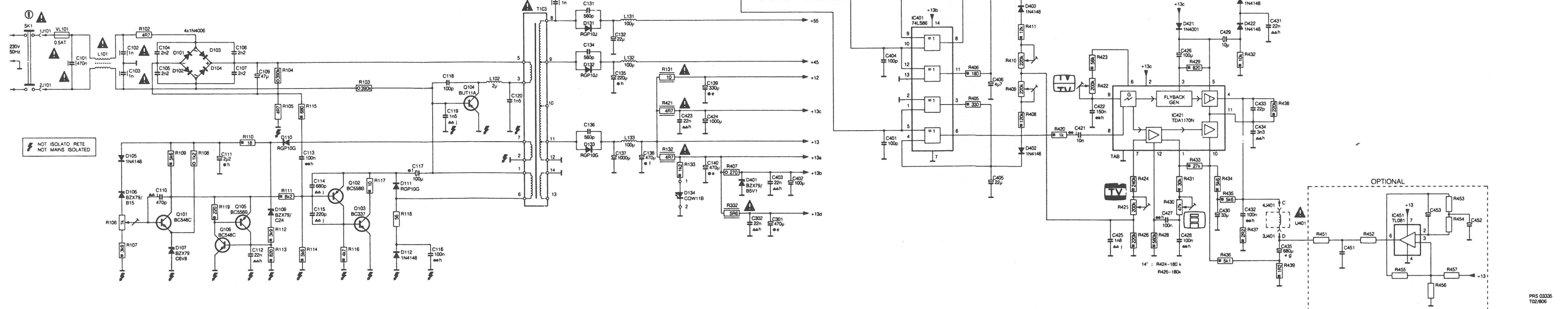

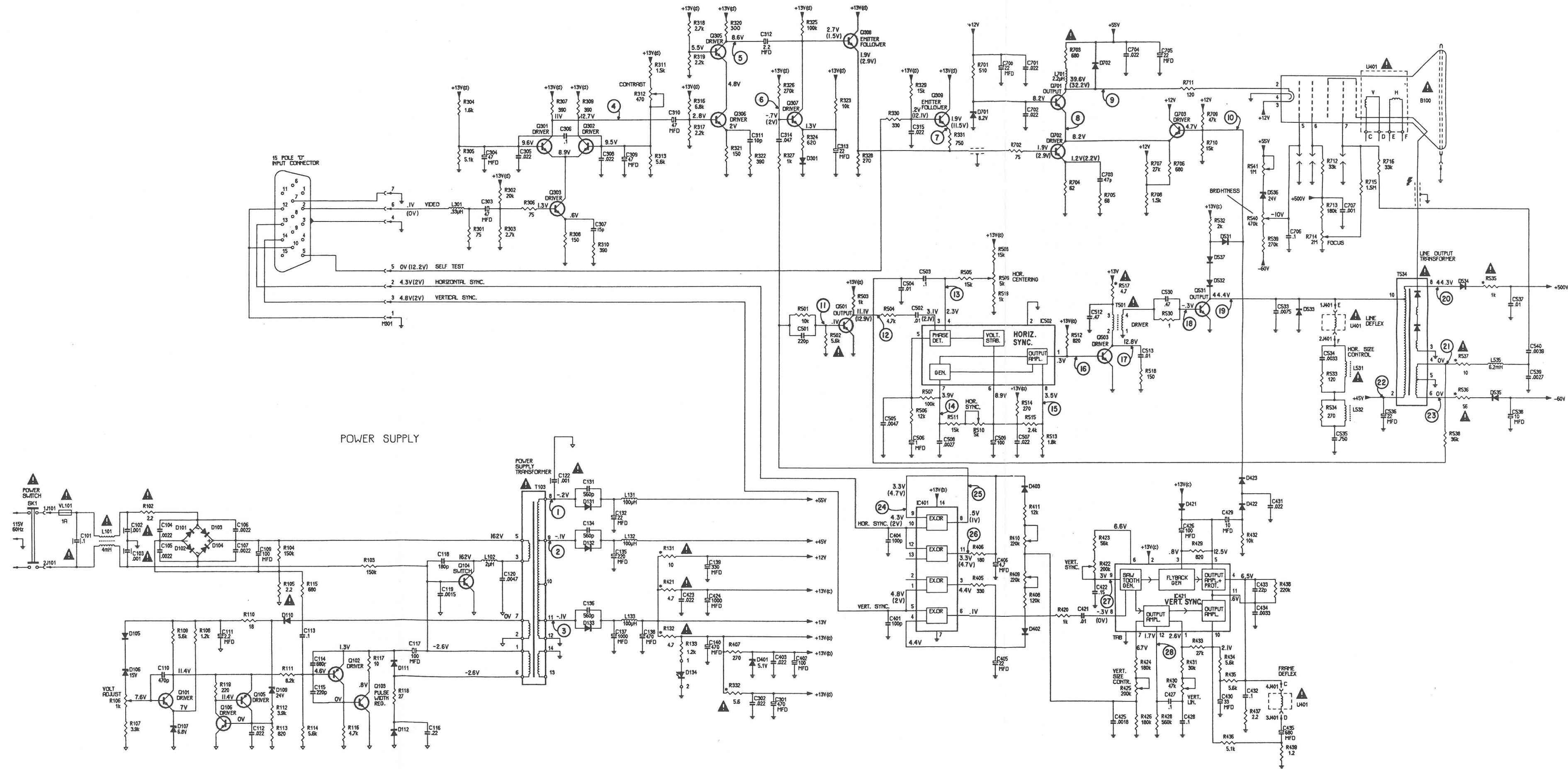

WAVEFORM PHOTOS (110V VERSION)

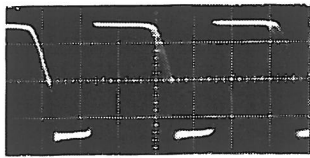

1. 160Vp-p 10uS

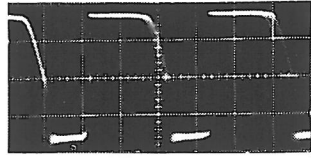

2. 120Vp-p 10uS

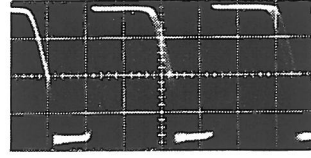

3. 40Vp-p 10uS

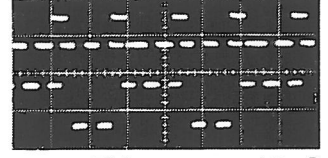

4. 1.5Vp-p 10uS

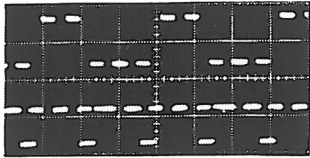

5. 2.8Vp-p 10uS

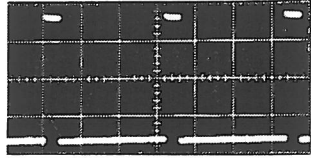

6. 3.4Vp-p 10uS

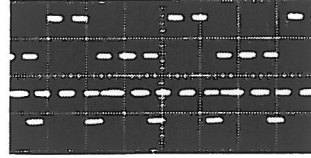

7. 2.8Vp-p 10uS

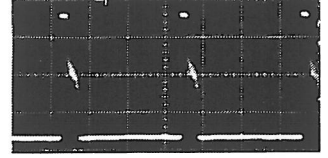

8. 4.5Vp-p 10uS

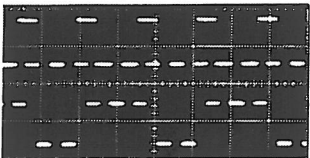

9. 3.4Vp-p 10uS

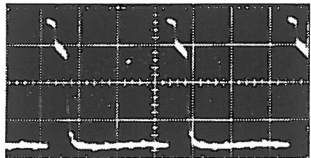

10. 10Vp-p 10uS

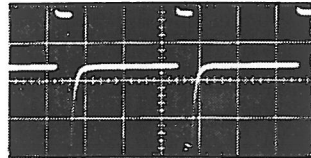

11. 19Vp-p 10uS

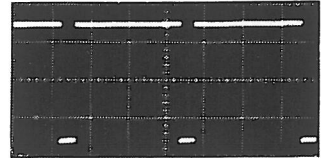

12. 13Vp-p 10uS

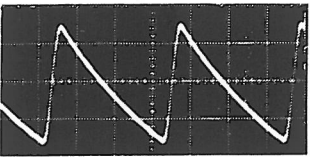

13. 1.5Vp-p 10uS

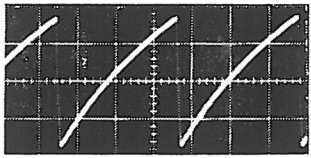

14. 3.5Vp-p 10uS

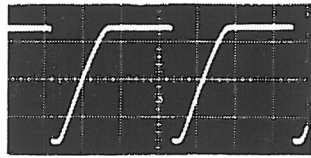

15. 1.3Vp-p 10uS

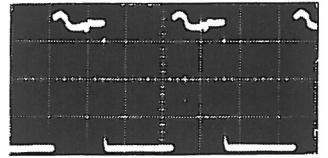

16. .7Vp-p 10uS

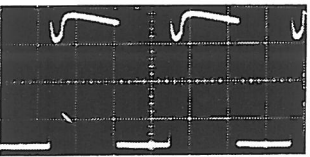

17. 25Vp-p 10uS

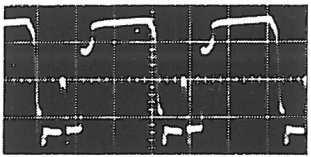

18. 3Vp-p 10uS

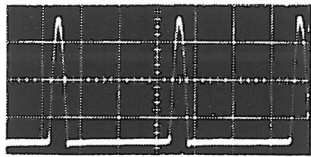

19. 480Vp-p 10uS

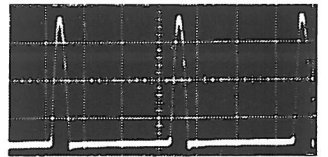

20. 630Vp-p 10uS

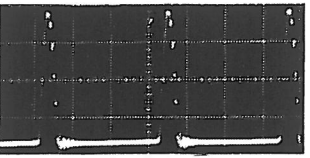

21. 210Vp-p 10uS

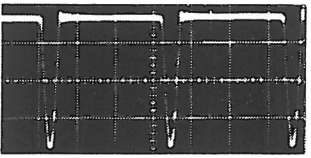

22. 75Vp-p 10uS

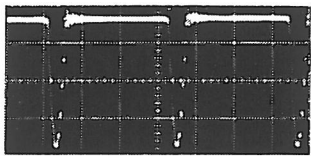

23. 82Vp-p 10uS

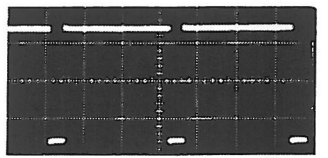

24. 5Vp-p 10uS

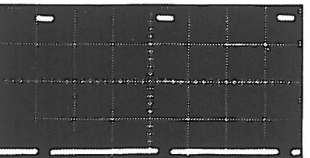

25. 3.8Vp-p 10uS

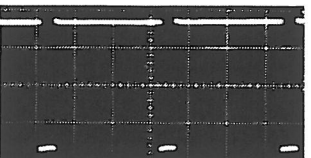

26. 3.5Vp-p 10uS

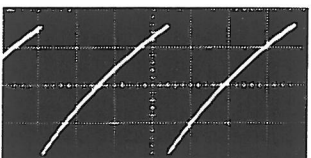

27. 2.7Vp-p 5mS

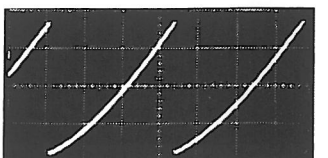

28. 4.5Vp-p 5mS

**ACKNOWLEDGEMENTS**

Reprinted with permission of North American Philips

Photograph on Page 1-2 — Rick Sterling



**Technical Training**  
Friedrich-Seele-Straße 10  
3300 Braunschweig

Tel.: (05 31) 89 50 63 • Fax: (05 31) 8 57 74