

Commodore

1935

Super VGA Color Monitor

Service Manual

1/92

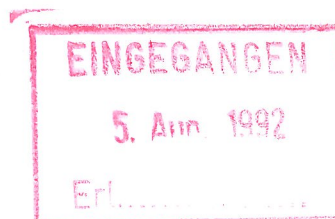

Produced By:

**Commodore International Spare Parts GmbH
Braunschweig, West Germany**

SERVICE MANUAL

**1935
SUPER VGA COLOR MONITOR**

JANUARY, 1992

PN-400418-01

INTERNATIONAL EDITION

SERVICE POLICY AND PART NUMBER INFORMATION MAY VARY ACCORDING TO COUNTRY. SOME PARTS MAY NOT BE AVAILABLE IN ALL COUNTRIES.

Commodore Business Machines, Inc.

1200 Wilson Drive, West Chester, Pennsylvania 19380 U.S.A.

Commodore makes no express or implied warranties with regard to the information contained herein. The information is made available solely on an as is basis, and the entire risk as to completeness, reliability, and accuracy is with the user. Commodore shall not be liable for any damages in connection with the use of the information contained herein. The listing of any available replacement part herein does not constitute in any case a recommendation, warranty or guaranty as to quality or suitability of such replacement part. Reproduction or use without express permission, of editorial or pictorial content, in any matter is prohibited.

This manual contains copyrighted and proprietary information. No part of this publication may be reproduced, stored in a retrieval system, or transmitted in any form or by any means, electronic, mechanical, photocopying, recording or otherwise, without the prior written permission of Commodore Electronics Limited.

Copyright © 1992 by Commodore Electronics Limited.
All rights reserved. Printed in U.S.A.

TABLE OF CONTENTS

SPECIFICATIONS 1

SAFETY PRECAUTIONS AND NOTICES..... 4

ALIGNMENT AND ADJUSTMENT..... 6

ASSEMBLY AND DISASSEMBLY..... 13

BLOCK DIAGRAM..... 14

TROUBLESHOOTING CHART..... 15

PARTS LIST..... 18

CIRCUIT DIAGRAM..... 19

SPECIFICATIONS

Application:	A typical data display device for graphics & text PC applications.
Power Input:	80 watts (nominal) AC rated voltage. Refer to R/C label.
Video Signals:	Analog: 0.7 Vp-p, RGB positive.
Sync. Signals:	Separate Sync: Horiz./Vert., TTL, positive or negative. Composite Sync.: Negative going TTL (MAC II).
Sync. Frequencies:	Horizontal: 31.468 KHz / 35.52 KHz Vertical: 50 - 87 Hz
Signal Connectors:	15-pin, D-shell connector. VGA to MAC II interchanger (optional).
Display Tube:	14" 90 degrees, 575R, 29.1o neck, 0.28mm dot pitch, in-line gun, non-glare screen. Type number: M34KBV80X11
Display Area:	240 x 180mm (H x V)
Display Colors:	Infinite
Display Characters:	80 char. x 60 rows on a 10x10 matrix.
Maximum Resolution:	1024 dots x 768 lines
Misconvergence:	Center Area: $\leq 0.3\text{mm}$ Corner Area: $\leq 0.4\text{mm}$
User Controls:	Power ON/OFF, Brightness, Contrast, Voltage Selector, Horiz. Phase, Vert. Size.



COMMODORE 1935 SUPER VGA COLOR MONITOR

- Service Controls: PWB-1002: R-BKG, G-BKG, B-BKG ,
R-Bias, G-Bias, B-Bias.
- PWB-1001: G1 Voltage Adjust.,
Pincushion, Horiz. Width, Horiz. Hold 1,
Horiz. Hold 2, Horiz. Phase 1, Horiz. Phase 2,
Vert. Size, Vert. Center, Vert. Linearity,
Vert. Hold, Screen.
- Environmental
Conditions: Operation: 10 to 35 degrees C ambient.
Storage: 0 to 65 degrees C ambient.
Humidity: 8% to 80% (non-condensing).
Altitude: up to 7000 ft. above sea-level.
- Dimensions: 388mm (H) x 370mm (W) x 420mm (D).
- Gross Weight: 14 kgs.

SIGNAL CABLE PIN CONNECTIONS

Pin	Signal	Pin	Signal
1	Red Signal	8	Blue Return
2	Green Signal	9	No Pin
3	Blue Signal	10	Digital Ground
4	Monitor Sense Ground to Pin 10	11	Jumper to Pin 10
5	Ground	12	No Pin
6	Red Return	13	Horizontal Sync.
7	Green Return	14	Vertical Sync.
		15	No Pin

SAFETY PRECAUTIONS AND NOTICES

SAFETY PRECAUTIONS

1. Observe all cautions and safety related notes located inside the monitor cabinet and on the monitor chassis.
2. Operation of the monitor outside its cabinet or with the cover removed involves the risk of shock from the monitor power supply. Repair work on the monitor should not be attempted by anyone who is not thoroughly familiar with all necessary safety precautions and procedures for working on high voltage equipment.
3. Do not install, remove, or handle the picture tube in any manner unless shatter-proof goggles are worn. People not so equipped should be kept at a distance during handling of the picture tube. Keep the picture tube away from the body during handling.
4. The picture tube is constructed to limit X-radiation to 0.5mR/HR at 300 micro-amperes anode current. For continued protection, use the recommended replacement tube only, and adjust the voltages so that the designated maximum rating at the anode will not be exceeded.

PRODUCT SAFETY NOTICE

Many electrical and mechanical parts in this chassis have been specially inspected for safety, and the protection afforded by them cannot necessarily be obtained by using replacement components rated for higher voltage, wattage etc. Before replacing any of these components, read the Spare Parts List at the end of this manual carefully. The use of substitute replacement parts which do not have the same safety characteristics as those specified in the Spare Parts List may result in shock, fire, X-radiation or other hazards.

SERVICE NOTES

1. When replacing parts or circuit boards, clamp the lead wires around the terminals before soldering.
2. When replacing a high wattage resistor (>0.5 W metal oxide film resistor) in the circuit board, keep the resistor about 1 cm (1/2") away from the circuit board.
3. Keep wires away from high voltage or high temperature components.
4. Keep wires in their original positions so as to minimize interference.

SAFETY TEST

Before returning a serviced monitor to the customer, a thorough safety test must be performed to verify that the monitor is safe to operate without danger of shock.

Always perform an AC current leakage check on the exposed metallic parts, such as screw heads, as follows:

1. Plug the AC line cord directly into a rated AC. Do not use a Line Isolation Transformer during this check).
2. Use an AC voltmeter having at least 5000 ohms per volt sensitivity as follows:
Connect a 1500 ohms 10 watt resistor, paralleled by a 0.15mfd, AC type capacitor between a known good earth ground (such as a water pipe or conduit etc.) and the exposed metallic part simultaneously. Measure the AC voltage across the combination of 1500 ohms resistor and 0.15mfd capacitor.
3. Reverse the AC plug at the AC outlet and repeat the steps for AC voltage measurements for each exposed metallic part.
4. Voltage measured must not exceed 0.3 volts RMS. This corresponds to 0.2 milli-amps AC. Any value exceeding this limit constitutes a potential shock hazard and must be corrected immediately.

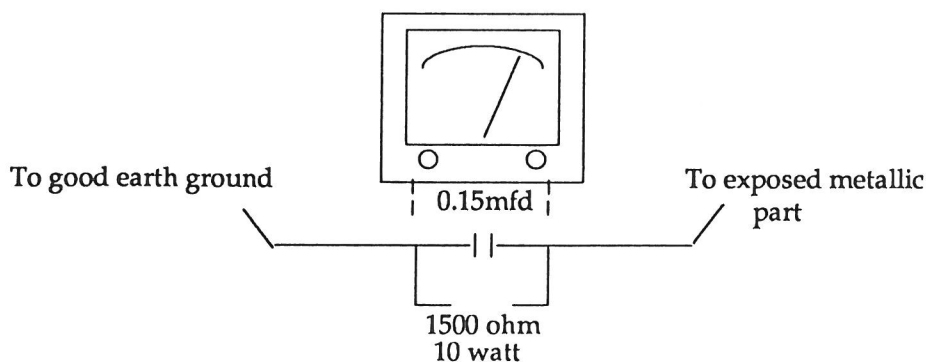

ALIGNMENT AND ADJUSTMENT

1. ADJUSTMENT CONDITIONS

Power Supply: AC 220V, 60 Hz

Warm-up Time: The monitor should be powered on for at least 15 minutes before any adjustments are made, except for convergence, when 30 minutes are required.

Signal Input:

1. Video: RGB Analog, 0.7 Vp-p, positive.
2. Sync. : Horiz. and Vert. separated, positive or negative.
Composite, negative going TTL (MAC II).
3. Scanning Frequencies: FH: 31.468 KHz / 35.52 KHz
FV: 50 - 87 Hz
4. All adjustments should be made using a signal of FH=31.468 KHz, unless otherwise defined.

2. Parameter list of signal timings generated:

1024x768 Interlaced Mode: (35.52 KHz)

Horiz. Sync. Polarity	POS
Vert. Sync. Polarity	POS
Total PELs per Line	1264
Active PELs per Line	1024
Line Blanking Time (PELs)	240
Line Sync. Pulse Width (PELs)	176
Line Front Porch Width (PELs)	8
Line Back Porch Width (PELs)	56
Total Lines per Frame	817
Active Lines per Frame	768
Fields per Frame	2
Field Blanking Time (E/O Lines)	25/24
Field Sync. Pulse Width (E/O Lines)	4
Field Front Porch Width (E/O Lines)	0.5/0.0
Field Back Porch Width (E/O Lines)	20.5/20
PEL Time (ns)	22.27
Total Line Time (us)	28.15
Total Frame Time (ms)	23.00
Frame Rate (Hz)	43.48

Vertical Lines	350	400	480	600
Horizontal Freq.	— 31.468 KHz —		35.52 KHz	
Sync. Polarity	POS	NEG	NEG	POS
A us	31.78	31.78	31.78	28.44
B us	3.81	3.81	3.81	2.00
C us	1.91	1.91	1.91	3.66
D us	25.42	25.42	25.42	22.22
E us	0.64	0.64	0.64	0.67
Vertical Freq.	60 Hz	70 Hz	60 Hz	56.25 Hz
Sync. Polarity	NEG	POS	NEG	POS
O ms	14.27	14.27	16.68	17.78
P ms	0.06	0.06	0.06	0.06
Q ms	1.91	1.11	1.05	0.63
R ms	11.12	12.71	15.25	17.07
S ms	1.18	0.38	0.32	0.03

HORIZONTAL

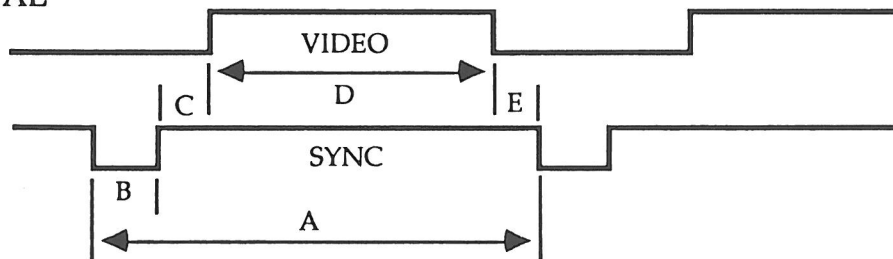

VERTICAL

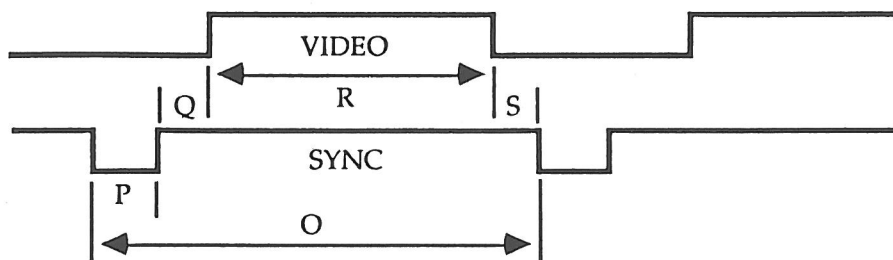

3. ADJUSTMENT EQUIPMENT

- a. Volt-ohm-A meter (Sanwa FD-750C or equivalent).
- b. 30KV high voltage probe (HP34111A).
- c. Oscilloscope (TEK2235 or equivalent).
- d. White balance adjuster (Minolta Color Analyzer II).
- e. Signal generator (IBM PC with VGA card or equivalent).
- f. Screwdriver.

**4. SWITCHING POWER SUPPLY - Regulator Adjustment
(PWB1001)**

The regulated B+ control has been preset in the factory and needs no adjustment. However, if any repairs are made on the equipment, the following readjustment procedures are recommended.

- a. Allow the monitor to warm-up for about 5 minutes.
- b. Do not apply any signal to the monitor.
- c. Connect a DC meter to C820 (on the main PCB), and adjust VR818 for 84V DC.
- d. If a fuse is broken during adjustment, remember to replace it with the exact same type of fuse.

5. ALIGNMENT PROCEDURES

A) SYNCHRONIZATION ADJUSTMENT

Input Signal: Cross Hatch Pattern

640 mode: Adjust Horiz. Hold 1 [VR405] to obtain horiz. freq.
31.468 KHz (+/-10%).

800 & 1024 modes: Adjust Horiz. Hold 2 [VR414] to obtain horiz. freq.
35.52 KHz.

640 mode: Adjust Vert. Hold [VR304] until the cross hatch pattern is stable.

B) DISPLAY DATA POSITION ADJUSTMENT

Input Signal: Cross Hatch Pattern

1. Set Brightness to maximum.

2a. 31.468 KHz mode: Adjust Horiz. Phase 1 [VR411] & Vert. Center
[VR318] so that the display data is central on the screen.

b. 35.52 KHz modes: Adjust Horiz. Phase 2 [VR424] & Vert. Center
[VR318] so that the display data is central on the screen.

C) PICTURE SIZE ADJUSTMENT

Input Signal: Cross Hatch Pattern

Horiz. Width:

350 mode: Adjust L402 so that the horiz. width of the picture
is 240mm +/- 3mm

Vert. Height:

350 mode: Adjust VR124 so that the vert. height of the picture
is 180mm +/- 3mm

400 mode: Adjust VR125 so that the vert. height of the picture
is 180mm +/- 3mm

480 mode: Adjust VR126 so that the vert. height of the picture
is 180mm +/- 3mm

768 mode: Adjust VR127 so that the vert. height of the picture
is 180mm +/- 3mm

Mac II mode: Adjust VR128 so that the vert. height of the picture
is 3/4 the horiz. width.

D) WHITE BALANCE ADJUSTMENT

Input Signal: Full White Video - VGA mode
Drive VRs: VR502, VR532, VR562.
Bias VRs: VR910, VR940, VR970.

- 1a. Set Brightness & Contrast to minimum.
 - b. First adjust VR940 to its center position.
Then adjust VR970 so that $Y = 0.329$
and adjust VR910 so that $X = 0.313$
- 2a. Set Brightness to center detent & Contrast to maximum.
 - b. Adjust VR532 for 45Vp-p of the G. gun input at the cathode.
- 3a. Set Brightness to center detent & Contrast to 10 Fl.
 - b. First adjust VR562 so that $Y = 0.329$
then adjust VR502 so that $X = 0.313$
- 4a. Set Brightness to maximum & the G2 voltage just before the raster appears.
 - b. Check the white balance in the VGA mode.
- 5a. Set Brightness just before the raster disappears.
 - b. Repeat steps 2b. to 5b. until the best white balance is obtained.

E) FOCUS ADJUSTMENT

Input Signal: Dot Test Pattern

1. Set Brightness & Contrast for a normal display.
2. Adjust the focus control at the high voltage resistor block to obtain the best focus over the entire display area.

F) STATIC CONVERGENCE ADJUSTMENT

NB: The monitor should be operated for at least 30 mins. before any convergence adjustments are made.

Input Signal: Cross Hatch Pattern

1. Set Brightness & Contrast so that a well-defined pattern is obtained.
2. Ensure that the convergence magnets on the CRT are in the correct position.

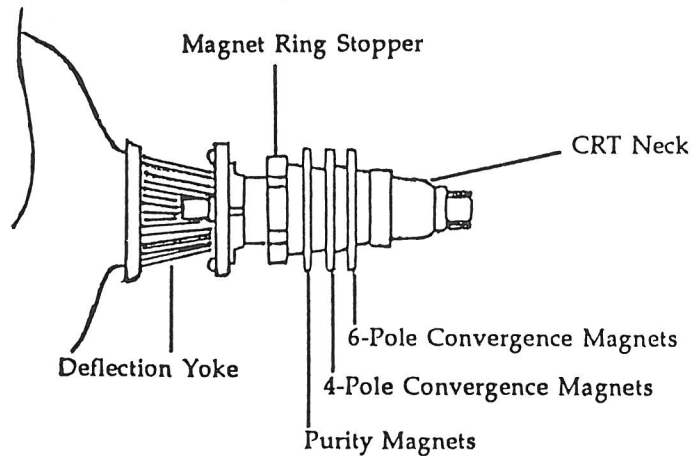

3. Turn the 2 tabs of the 4-pole magnets independently to adjust their angles. Align the red & blue vert. lines at the center of the screen.
4. Turn the 2 tabs of the 4-pole magnets simultaneously to keep their angles constant. Align the red & blue horiz. lines at the center of the screen.
5. Turn the 2 tabs of the 6-pole magnets independently to superimpose the red/blue vert. line on the green one.
6. Turn the 2 tabs of the 6-pole magnets simultaneously to superimpose the red/blue horiz. line on the green one.
7. Repeat steps 3, 4, 5 & 6 until the best convergence is obtained.
NB: The 4-pole magnets & the 6-pole magnets interact, making dot movements complex.

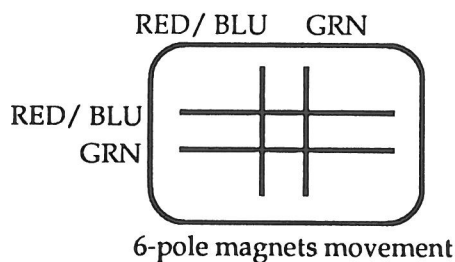
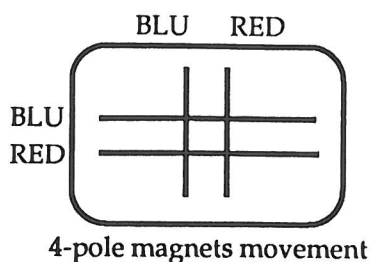

G) DEGAUSSING

Degaussing is required when poor color purity appears on the screen. This monitor uses an automatic degaussing circuit that is activated at power ON. Automatic degaussing will be fully functional within 15 minutes.

The degaussing effect is confined to the picture tube since the coils are mounted at the back of the tube. Should any part of the chassis or cabinet become magnetized, it will be necessary to degauss the affected area with a manual degaussing coil.

Manual Degaussing

- a. Apply line voltage to the degaussing coil and move it in a rotary motion over the front, sides, and top of the monitor. The coil should be kept away from the rear of the monitor to avoid damaging the magnetic neck components.
- b. Slowly rotate and back the coil away from the monitor to about 6 feet beyond the point where no effect on the CRT will be noticeable.

For proper degaussing, it is essential that the field be gradually reduced by moving the coil slowly away from the monitor. The degaussing coil must never be shut off or disconnected while near the monitor, as this would introduce a strong field instead of cancelling the effect of the stray fields.

ASSEMBLY AND DISASSEMBLY

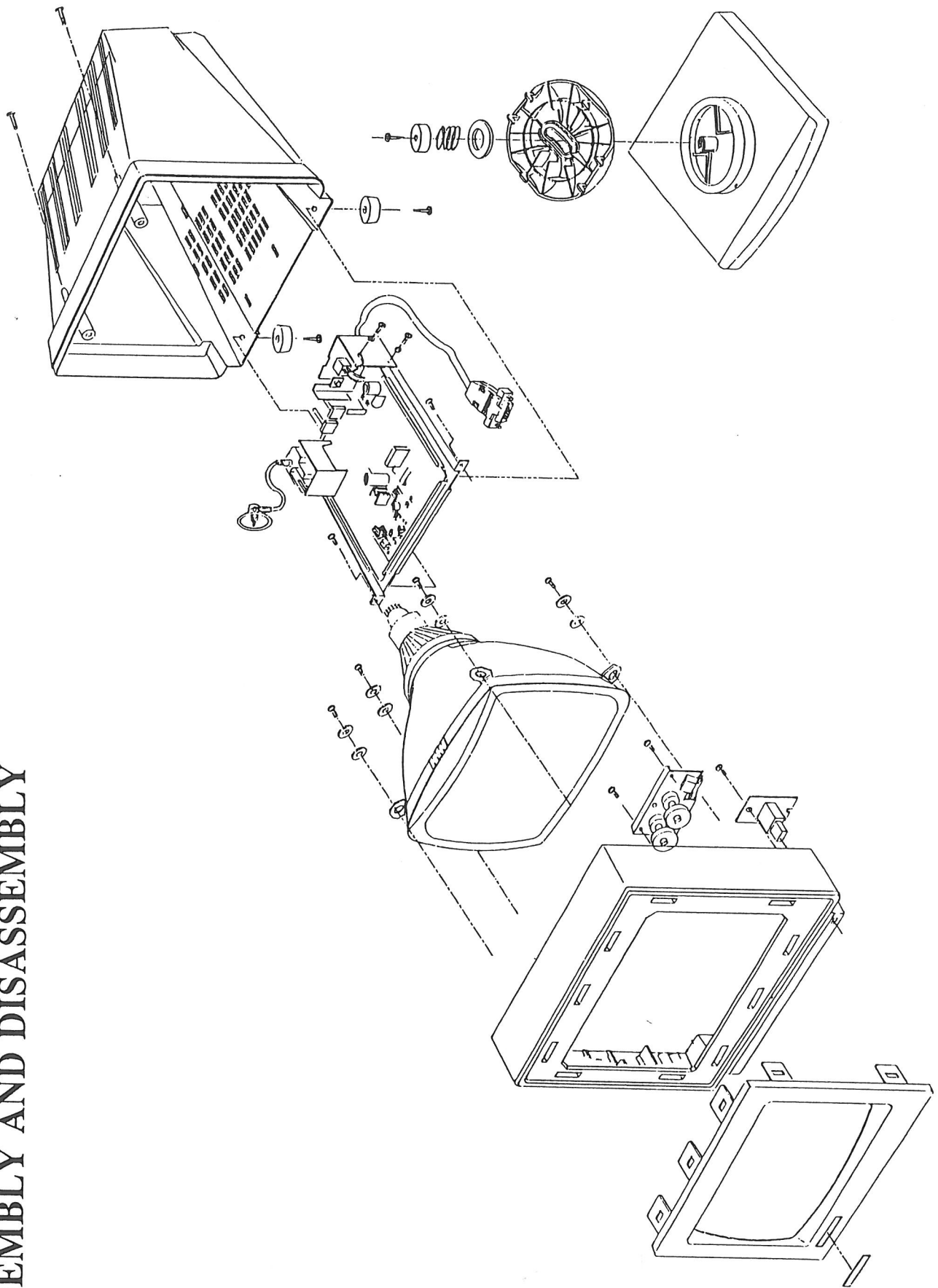

BLOCK DIAGRAM OF CM-1414E COLOR MONITOR

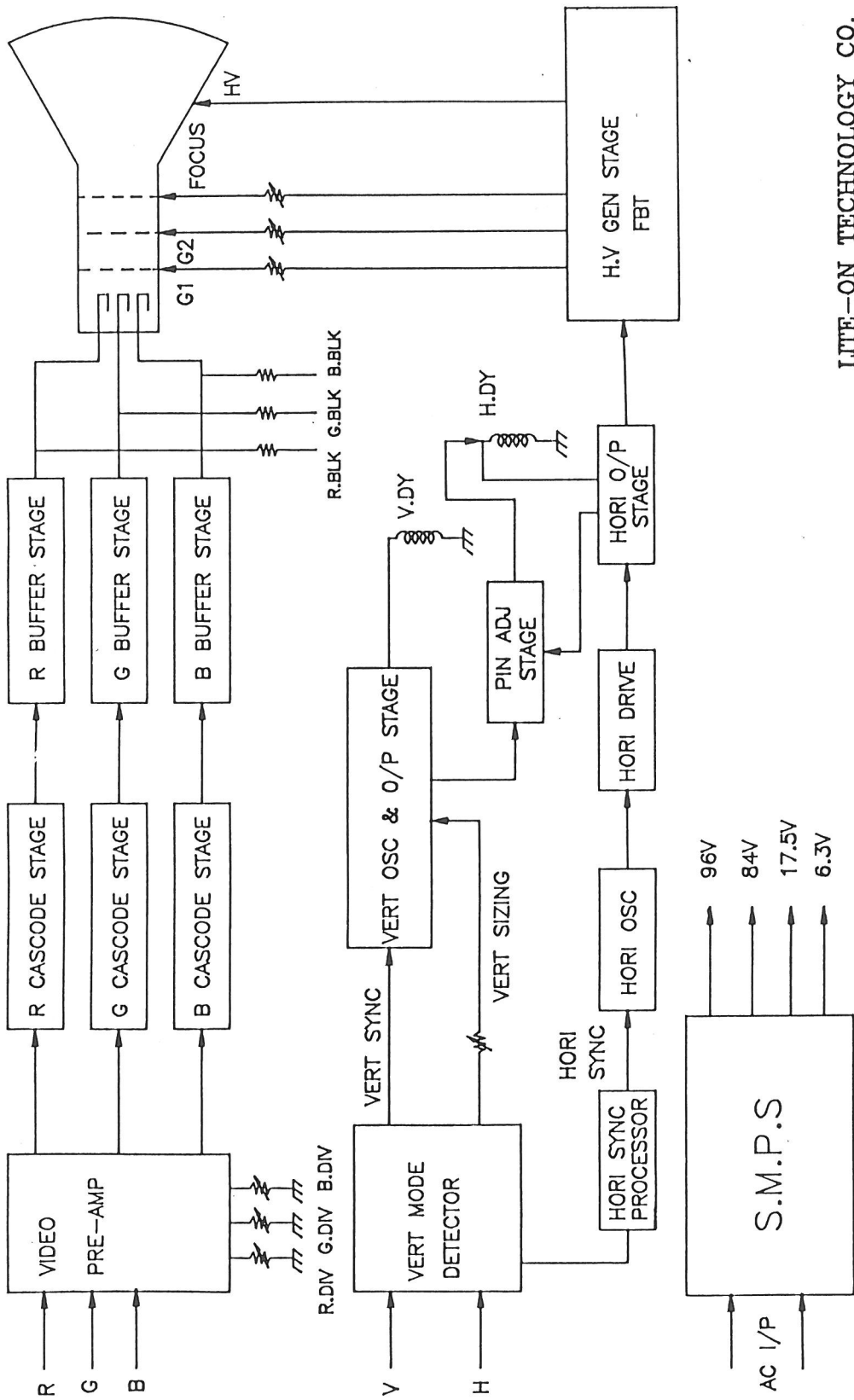

LITE-ON TECHNOLOGY CO.

TROUBLE-SHOOTING CHART

1. NO RASTER

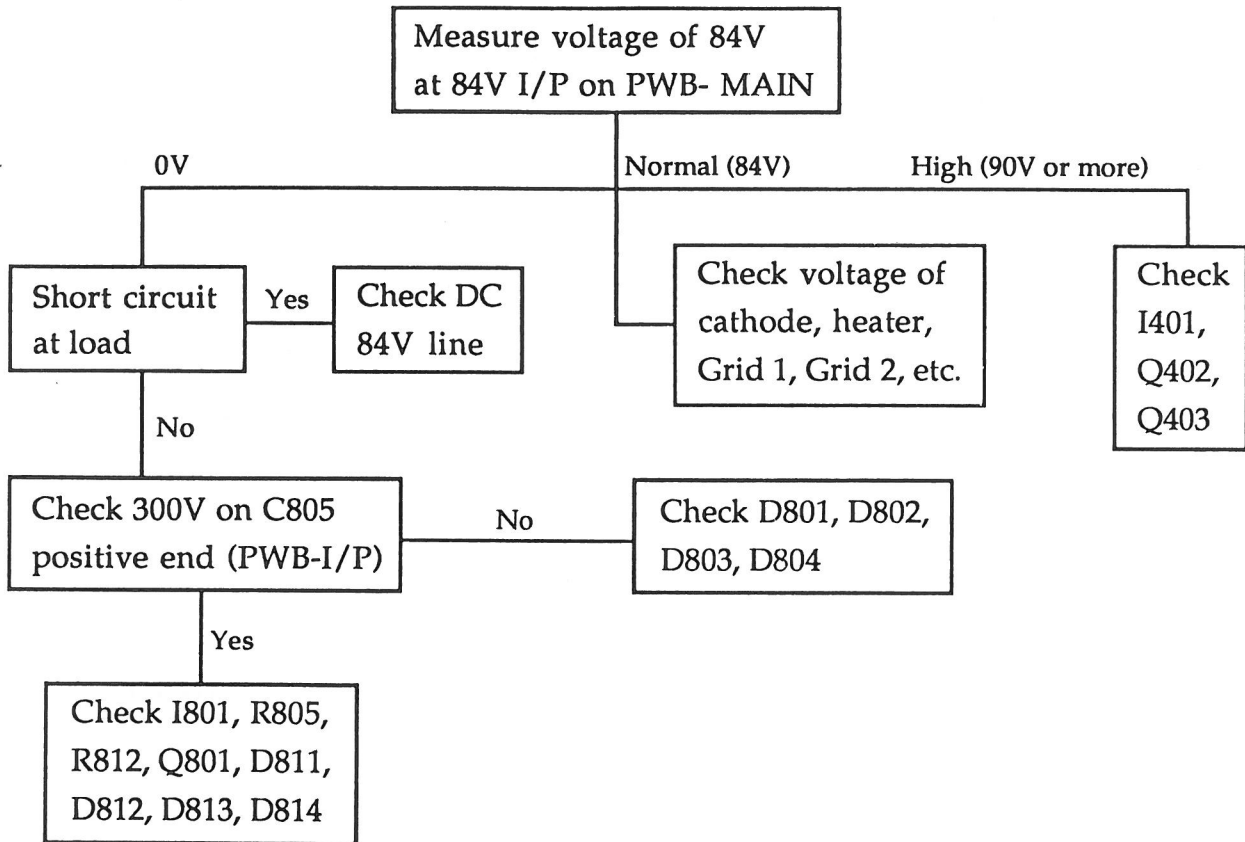

2. AUTOMATIC BRIGHTNESS LIMITER NOT FUNCTIONING

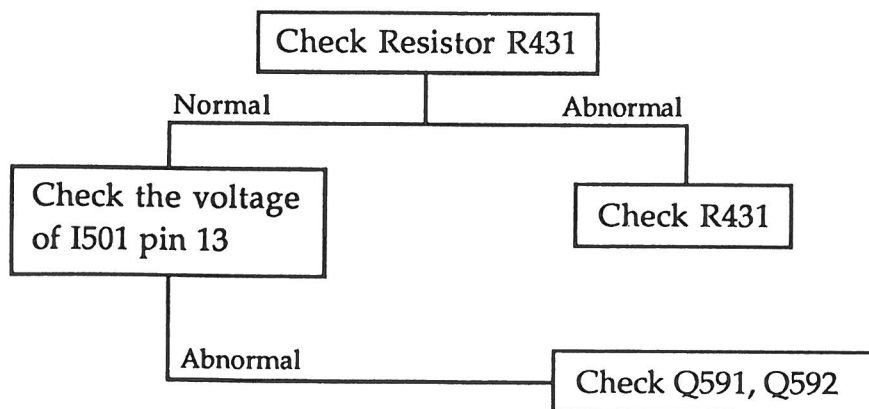

3. NO VERTICAL SCAN (RASTER IS ONE HORIZ. LINE)

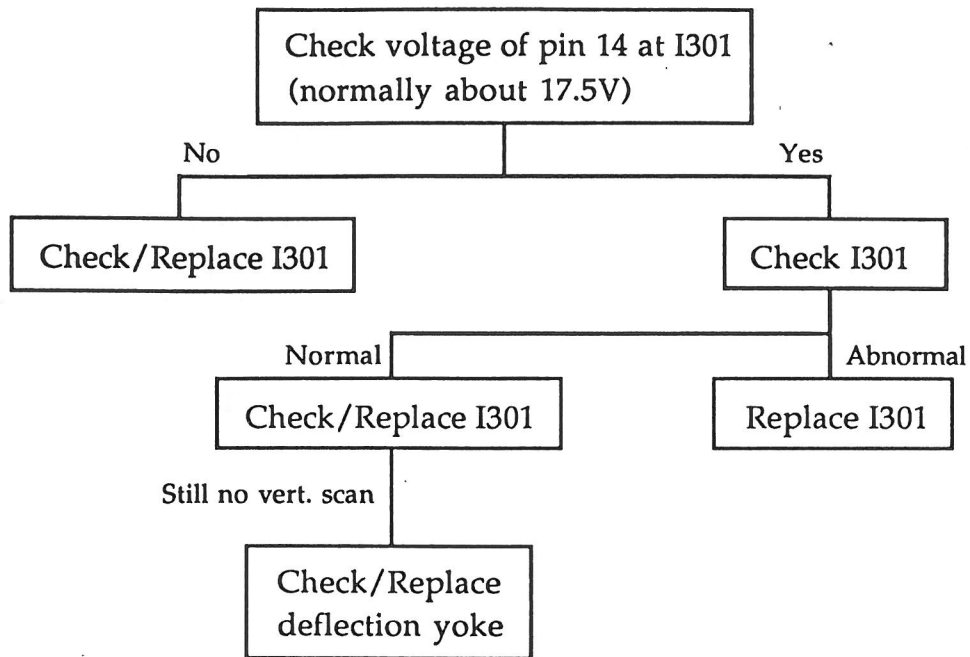

4. OUT OF HORIZ. SYNC.

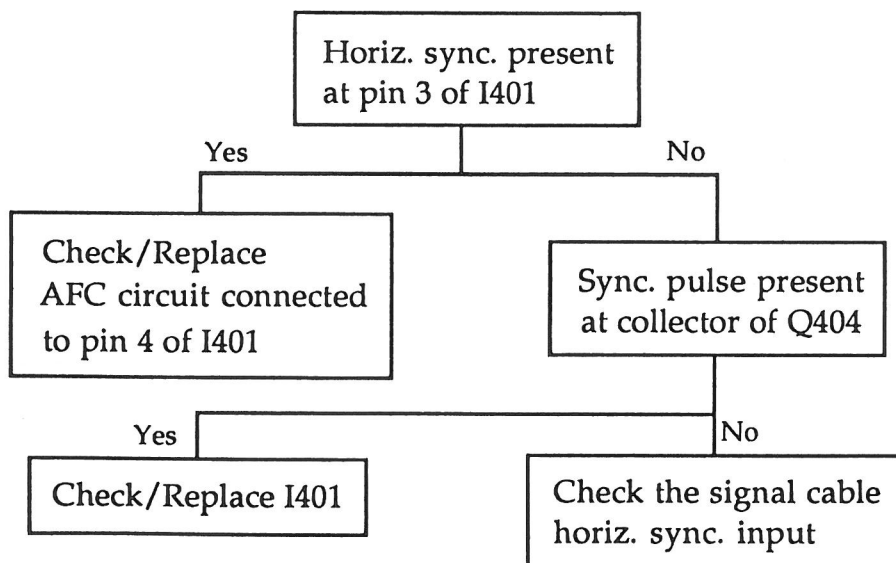

5. OUT OF VERTICAL SYNC.

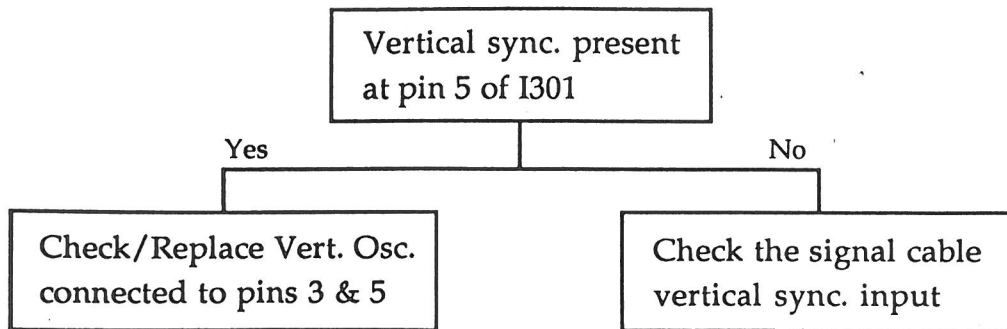

6. VIDEO AMP ABNORMAL

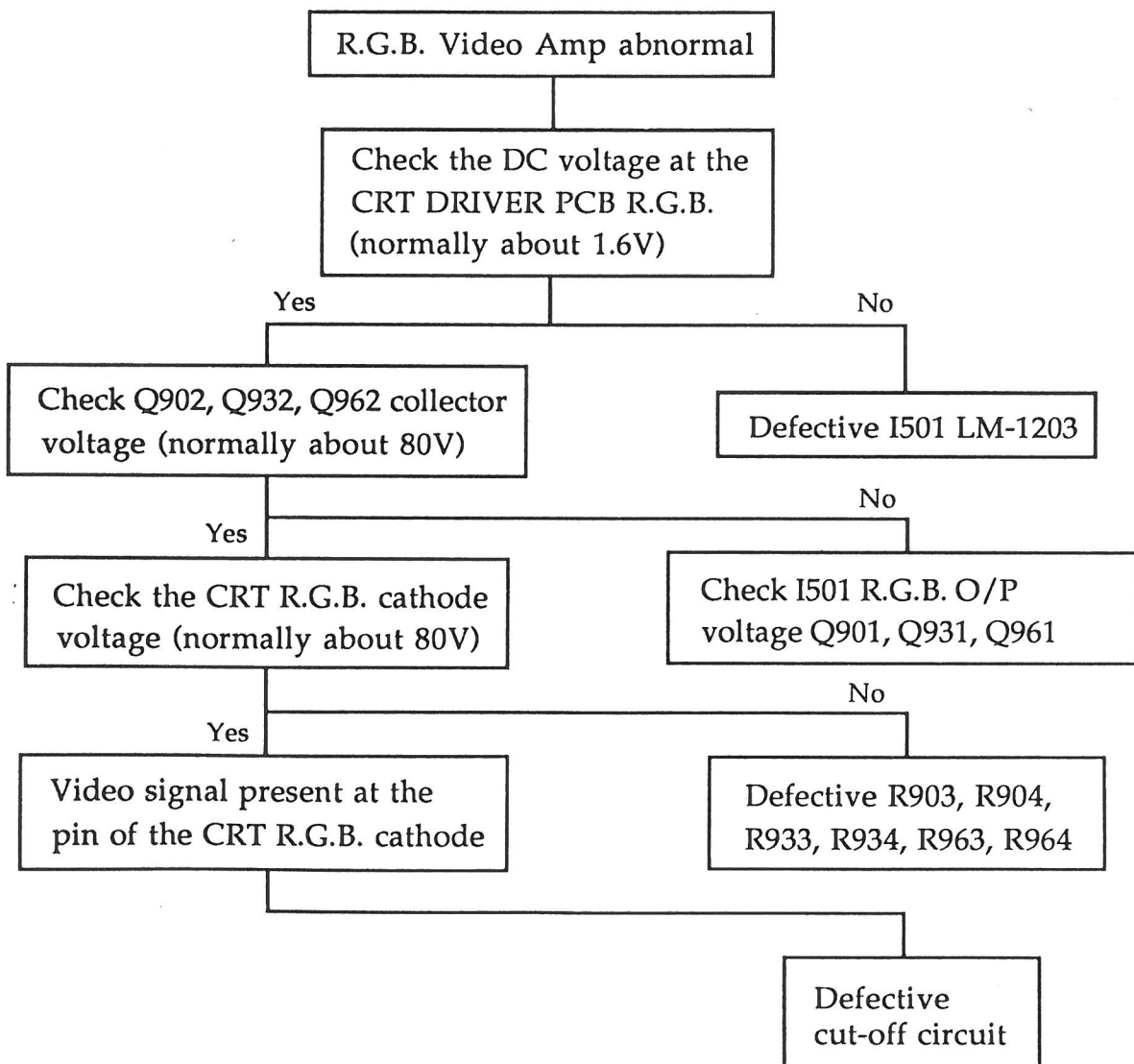

Commodore International Spare Parts List 1935 PCB Assembly

Commodore part numbers are provided for reference only and do not indicate the availability of spare parts from Commodore. Industry standard parts (Resistors, Capacitors, Connectors) should be secured locally. Part number information may vary according to country, some parts may not be available in all countries.

602318-001	FBT	T403	602318-023	TR NPN	Q402
602318-002	RES CF	R430	602318-024	TR NPN	Q403
602318-003	RES CF	R429	602318-025	TR NPN	Q902, Q932, Q962
602318-004	RES CF	R813	602318-026	TR NPN	Q901, Q931, Q961
602318-005	RES FUS	R811	602318-027	TR NPN	Q904, Q934, Q964
602318-006	RES MOF	R805	602318-028	TR NPN	Q406
602318-007	RES MOF	R812	602318-029	TR NPN	Q408-409
602318-008	RES MOF	R814	602318-030	TR PNP	Q303
602318-009	VR (SIZE)	R133	602318-031	TR PNP	Q592
602318-010	VR (PHASE)	R424, R445	602318-032	TR PNP	Q903, Q933, Q963
602318-011	VR	R818	602318-033	TR PNP	Q407
602318-012	CAP ALU	C807	602318-034	IC PWR	I801
602318-013	CAP MEF	C808	602318-035	IC LINEAR	I301
602318-014	CAP CD	C818	602318-036	IC LINEAR	I401
602318-015	CAP CD	C507, 509	602318-037	IC LINEAR	I108
602318-016	DIODE SW	D801-804	602318-038	IC LINEAR	I501
		D805-806	602318-039	IC LINEAR	I102
602318-017	DIODE SW	D101, D104-106	602318-040	IC LINEAR	I103
		D811-814	602318-041	IC LINEAR	I107
602318-018	DIODE SW	D102-103	602318-042	IC DIGITAL	I101
602318-019	DIODE SW	D817	602318-043	IC DIGITAL	I106
602318-020	THYRISTOR SCR	Q802	602318-044	IC DIGITAL	I104-105
602318-021	TR NPN	Q801	602318-045	FUSE (4A, 250V)	F801
		Q101, Q302, Q304			
602318-022	TR NPN	Q404-405, Q591, Q593			

Cabinet Parts

602318-046	FRONT BEZEL	602318-049	PEDESTAL
602318-047	BACK COVER	602318-050	CRT
602318-048	NAMEPLATE		

COLOR MONITOR CM1414ELR/EN CIRCUIT DIAGRAM

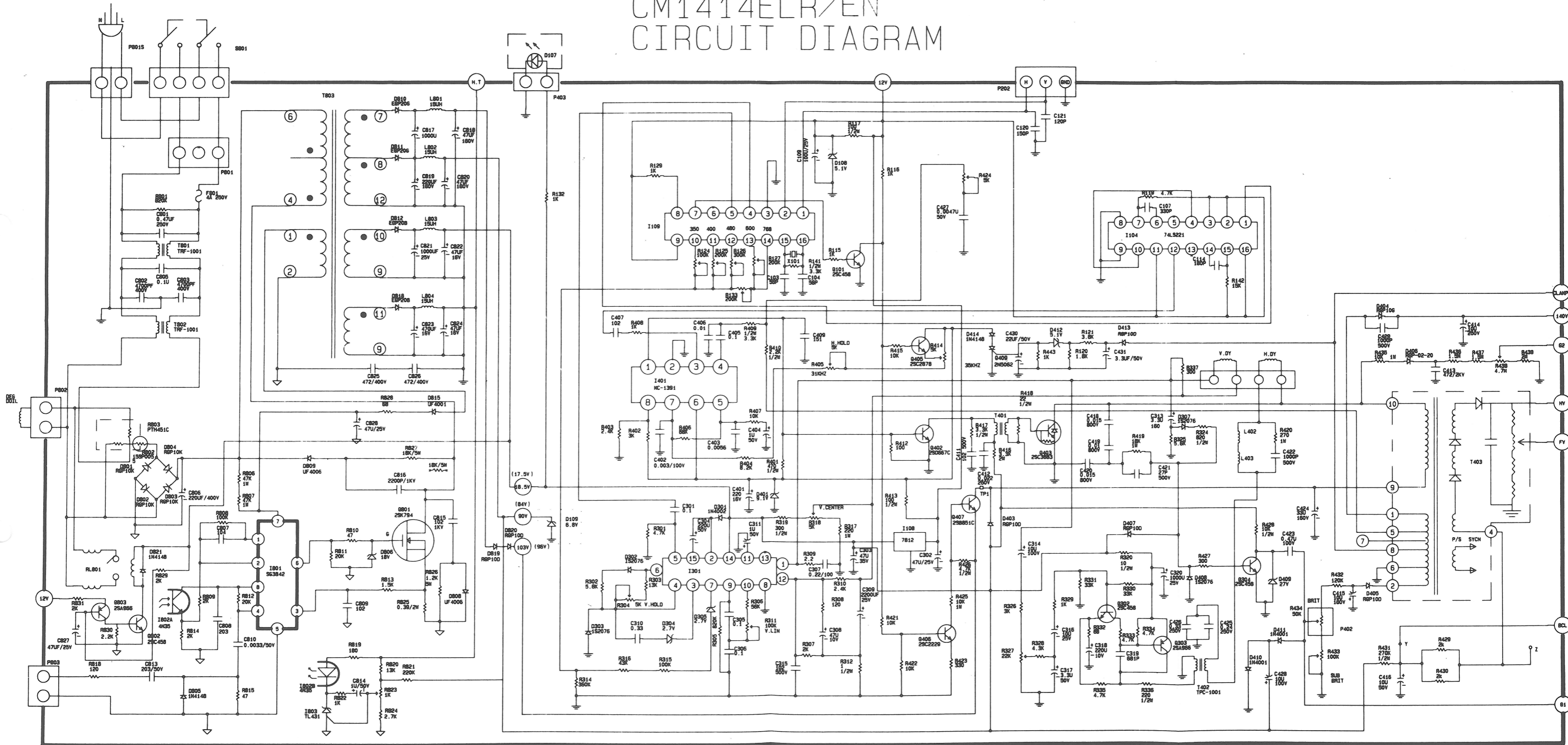



Technical Training
Friedrich-Seele-Straße 10
3300 Braunschweig

Tel.: (05 31) 89 50 63 · Fax: (05 31) 8 57 74