

SYSTEM SCHEMATICS

A2091

TABLE OF CONTENTS

DECEMBER, 1989 PN-314674-01

 **Commodore**

SYSTEM SCHEMATICS

A2091

TABLE OF CONTENTS

DECEMBER, 1989 PN-314674-01

* PARTS LIST *

INTERNATIONAL EDITION

COMMODORE "INTERNATIONAL EDITION" SERVICE MANUALS CONTAIN PART NUMBER INFORMATION WHICH MAY VARY ACCORDING TO COUNTRY. SOME PARTS MAY NOT BE AVAILABLE IN ALL COUNTRIES.

PN-314674-02 FOR DETAILED OPERATIONS.

Commodore Business Machines, Inc.
1200 Wilson Drive, West Chester, Pennsylvania 19380 U.S.A.

Commodore makes no expressed or implied warranties with regard to the information contained herein. The information is made available solely on an as is basis, and the entire risk as to quality and accuracy is with the user. Commodore shall not be liable for any consequential or incidental damages in connection with the use of the information contained herein. The listing of any available replacement part herein does not constitute in any case a recommendation, warranty or guaranty as to quality or suitability of such replacement part. Reproduction or use without expressed permission, of editorial or pictorial content, in any matter is prohibited.

This manual contains copyrighted and proprietary information. No part of this publication may be reproduced, stored in a retrieval system, or transmitted in any form or by any means, electronic, mechanical, photocopying, recording or otherwise, without the prior written permission of Commodore Electronics Limited.

Copyright © 1989 by Commodore Electronics Limited.
All rights reserved.

A2091-40 SPECIFICATIONS

DESCRIPTION

This specification describes the Functional Requirements for an A2091-40 hard disk upgrade kit.

CONTENTS

The A2091-40 hard disk upgrade kit contains the following items:

- A. A2091 Hard disk controller board
- B. Cables for card-mounting hard disk drive
- C. Quantum pro-drive 400 hard disk drive
- D. Cable for mounting hard drive in drive bay
- E. Shock mounts for hard drive
- F. Softening rod for A2000
- G. Foam pad for A2000
- H. A2000HD sticker for front panel of A2000

An A2091-40 upgrades an A2000 to an A2000HD.

PARAMETERS

Dimensions:	PCB 12.25 inches by 3 inches
Weight:	5 lbs.
Power requirements:	
PCB:	+12V 0.0A, +5V 1.0A
Hard drive:	+12V 1.0A, +5V 0.5A, +12V 0.6A Normal operation
Hard drive features:	42 MB formatted capacity, 15 ms seek time, supports disconnect/reconnect, 64K byte disk local cache, 11

TABLE OF CONTENTS

- SPECIFICATIONS
- PARTS LISTS
- SCHEMATICS

NOTE

**PLEASE REFERENCE A2091 USER MANUAL
PN-363227-02 FOR DETAILED OPERATIONS.**

DESCRIPTION

This specification describes the Functional Requirements for an A2091-40 hard disk upgrade kit.

PARAMETERS

Dimensions:	PCB 12.25 inches by 3 inches
Weight:	1 lb.
Power Requirements:	
Without a hard drive mounted to card:	
+12V 0.0 A	
+5V 1.0 A	
With hard drive mounted to card:	
+12V 2.5 A max startup, 0.9 A max continuous	
+5V 2.5 A continuous	
Features:	Hard disk controller for SCSI or XT style drives; Sockets for up to 2 Mbytes fast RAM; Auto-boot ROMs; Boots directly into Fast File System; Rear socket permits connection of Microware style SCSI expansion devices; Space on card to mount user's own 3.5" hard drive

A2091-40 SPECIFICATIONS

DESCRIPTION

This specification describes the Functional Requirements for an A2091-40 hard disk upgrade kit.

CONTENTS

The A2091-40 hard disk upgrade kit contains the following items:

- A. A2091 Hard disk controller board
- B. Cables for card-mounting hard disk drive
- C. Quantum pro-drive 40S hard disk drive
- D. Cable for mounting hard drive in drive bay
- E. Shock mounts for hard drive
- F. Stiffening rod for A2000
- G. Foam pad for A2000
- H. A2000HD sticker for front panel of A2000

An A2091-40 upgrades an A2000 to an A2000HD.

PARAMETERS

- Dimensions: PCB 13.25 inches; Hard drive 6 inches by 4.25 inches by 2 inches
- Weight: 5 lbs.
- Power requirements:
 - PCB: +12V 0.0A, +5V 1.0A
 - Hard drive: +12V 1.6A, +5V 0.7A Power up; +12V 0.8A, +5V 0.6A Normal operation
- Hard drive features: 42 MB formatted capacity; 19 ms seek time; supports disconnect/reselect; 64K byte look-ahead cache; 1:1 interleave

A2091 SPECIFICATIONS

DESCRIPTION

This specification describes the Functional Requirements for an A2091 hard disk controller assembly.

PARAMETERS

- Dimensions: PCB 13.25 inches by 5 inches
- Weight: 1 lb.
- Power Requirements:
 - Without a hard drive mounted to card:
 - +12V 0.0 A
 - +5V 1.0 A
 - With hard drive mounted to card:
 - +12V 2.5 A max startup, 0.9 A max continuous
 - +5V 2.5 A continuous
- Features: Hard disk controller for SCSI or XT style drives; Sockets for up to 2 MByte fast RAM; Auto-boot ROMs; Boots directly into Fast File System; Rear socket permits connection of Macintosh style SCSI expansion devices; Space on card to mount user's own 3.5" hard drive

JUMPERS

JP1 is used to set the amount of memory on the board. It has 4 positions that represent no memory, 512K, 1M and 2M of memory.

JP2 is used to enable and disable the auto-boot ROMs. The ROMs must be disabled when the board is installed in an A2000 with KS1.2 ROMs. The position marked "AUTO" enables the auto-boot ROMs and the position marked "DIS" disables the autoboot ROMs.

JP3 determines the interrupt level that the board generates and is not user adjustable. It is factory wired to INT2.

JP5 is a software readable set of 3 jumpers. The function depends on the driver software, but with V4.4 of the driver the function is as follows:

Jumper 1:	Enable Multiple LUNs
Jumper 2:	Enable long boot timeout, disable parity check
Jumper 4:	Undefined

JP201 determines the clock rate fed into the WD33C93 SCSI controller IC. It is factory wired for a 7 MHz clock rate and is not user adjustable. If an end user would like to replace the standard WD33C93 with a high speed version of the part, the trace between the upper 2 pins of JP201 can be cut, and the lower 2 pins wired together. This would result in a 14 MHz clock rate which would effectively double SCSI throughput given a hard drive that can operate at that speed.

Factory settings are as follows:

JP1	OK (no memory)
JP2	DIS (Autoboot disabled)
JP3	INT2
JP5	ALL 3 functions disabled
JP201	7 MHz

CONNECTORS

CN1 (Not labeled on board) 100 pin Amiga edge card connector
Designed to plug into a standard A2000 100 pin Amiga slot.

CN2 XT LED

This is designed to accept the plug from the hard disk LED on the front panel of the A2000 if the user is using an XT drive. This connector will light the front panel LED whenever the XT drive is accessed.

CN3 SCSI LED

This is designed to accept the plug from the hard disk LED on the front panel of the A2000 if the user is using a SCSI drive. This connector will light the front panel LED whenever any SCSI device is accessed.

CN4 XT drive connector

This 40 pin connector is designed to attach to a ribbon cable that connects to an XT hard drive.

CN5 External SCSI connector

This DB25 connector is designed to connect the A2091 to external SCSI devices. It uses a pinout identical to the Apple Macintosh (R) SCSI connector and has the capability of connecting to any peripheral that is designed to connect to the Macintosh (R). Up to 7 external devices may be connected by daisy-chaining.

CN6 Internal SCSI connector

This 50 pin header is designed to attach to 1 or more (up to 7) internal SCSI devices. Multiple devices are connected by crimping multiple connectors onto 1 ribbon cable.

CN7 Power connector

This 4 pin molex connector supplies power to a 3.5" hard drive that the user may install on the A2091. The maximum power that may be drawn from this connector is as follows:

+12V: 2.5A max startup (8 sec), 0.9A max continuous; +5V: 1.5A max continuous

MOUNTING OF HARD DRIVE

Space is provided on the A2091 for the end user to mount a 3.5 inch hard drive. Mounting hardware is not included, and a cable is required to allow the hard drive to draw its power from the A2091, CPN 312646-01.

A2091 MAJOR PARTS LIST

313441-01	A2091-40 SHIPPING ASSEMBLY-U.S.
313441-02	A2091-40 SHIPPING ASSEMBLY-GERMANY
313441-03	A2091-40 SHIPPING ASSEMBLY-EFIGS.
313441-04	A2091-40 SHIPPING ASSEMBLY-SCANDI.
313441-05	A2091-40 SHIPPING ASSEMBLY-CANADA
313441-06	A2091-40 SHIPPING ASSEMBLY-AUSTRALIA
363243-01	BULK PACKING BOX
363242-02	PACKING BOX
318900-01	WARRANTY CARD U.S.
318882-01	WARRANTY CARD CANADA
318884-01	WARRANTY CARD AUSTRALIA
314877-02	SERVICE CENTER LIST U.S.
363033-01	A2091 USER MANUAL - EFIGS
363034-01	A2091 USER MANUAL - SCANDI
363227-02	C A2091 USER MANUAL - ENGLISH
252253-12	PLASTIC BAG
317806-01	C DISKETTE - INSTALL (US)
317807-01	C DISKETTE - INSTALL (GER)
318896-01	SOFTWARE LICENSE U.S. & CANADA
312341-02	DISKETTE REPLACEMENT CARD (US)
318556-02	DISKETTE REPLACEMENT CARD (CANADA)
312773-01	A2091 MAIN ASSEMBLY
312778-01	BRACKET, MOUNTING (ON MAIN ASSY)
906610-01	SCREW PHILIPS 6-32 (QTY = 4, MAIN ASSY)
905970-04	C NUT, KEPS 6-32 (QTY = 8, 4 ON MAIN ASSY, 4 FOR HD MOUNT)
316754-01	UPC LABEL
312646-01	C CABLE, POWER
312573-01	C CABLE, DATA 50P SHORT
313439-01	C CABLE, DATA 50P LONG
313440-01	C DRIVE, HARD 40MB SCSI QUANTUM
312713-01	C TIE BAR
312748-01	C ISOLATOR, VIBRATION
311554-01	C NAMEPLATE (AMIGA 2000HD STICKER)
312749-01	C FOAM SUPPORT
907272-02	C WASHER, FLAT
905960-04	C NUT, HEX M3
312769-01	C A2091 PCB ASSEMBLY - REV 4
312770-01	SCHEMATIC - PCB REV 4
312771-01	FABRICATION - PCB REV 4
312772-01	ARTWORK - PCB REV 4

COMPONENT PARTS LIST PCB ASSEMBLY #314386-03

Commodore part numbers are provided for reference only and do not indicate the availability of parts from Commodore. Industry standard parts (Resistors, Capacitors, Connectors) should be secured locally. Approved cross-references for TTL chips, Transistors, etc. are available in manual form through the Service Department, order #314000-01.

IC COMPONENTS			RESISTORS		
390333-03	16L8A RAM CONTROLLER	U5 PROGRAMMED INTO P/N 390071-02	901550-105	33 OHM 1/4W	R1,3,9-11
390332-01	74F158A	U8,U9	901550-01	1 K OHM 1/4W	R2,4,6,8,101
901521-46	74LS245	U2,U3	901550-49	100 OHM 1/4W	R12
390563-02	DMAC	U1	901550-131	56 OHM 1/4W	R7
390206-01	WD33C93	U4	380388-04	220/330 OHM/10PIN/8 ELEMENTS/SIP	RN1,RN3
901522-30	7407	U7	380388-01	220/330 OHM/6PIN/4 ELEMENTS/SIP	RN2
390617-01	74ALS32	U11	390227-04	33 OHM/10PIN/9 ELEMENT/SIP	RN6-RN8
901521-03	74LS08	U10	902410-08	4.7 K/10PIN/9 ELEMENT/SIP	RN4,RN5
901521-32	74LS86	U6	902410-06	3.3 K/10PIN/9 ELEMENT/SIP	RN201
390509-02	EPROM PROGRAMMED, ODD DRIVER	U12 PROGRAMMED INTO P/N 380204-01	CAPACITORS		
390508-02	EPROM PROGRAMMED, EVEN DRIVER	U13 PROGRAMMED INTO P/NB 380204-01	900020-09	.33uF, RADIAL LEAD, Z5U	C3-5,7-16,19,20,23,24,27,28,31
MISCELLANEOUS			251894-24	ELECT RADIAL LEAD 22uF 16V	C32,33
904150-08	SOCKET 20 PIN IC	U5,U14-29	CONNECTORS		
904150-05	SOCKET 28 PIN IC	U12,U13	903345-25	50 PIN, DIL	CN6
904150-06	SOCKET 40 PIN IC	U4	903345-20	40 PIN, DIL	CN4
390185-01	SOCKET 84 PIN IC	U1	903332-03	3 PIN, SIL	CN3,JP2
251842-02	FILTERS EMI 100pF	EMI 16	390241-05	25 PIN "D" SUB, RIGHT ANGLE	CN5
390017-01	DIODE 1N914	D1	903345-04	HEADER 2 BY 4	JP1
390331-01	CONN POWER 4 PIN	CN7	903345-03	HEADER 2 BY 3	JP5
316755-01	LABEL, FCC ID A2091		390333-01	JUMPER	

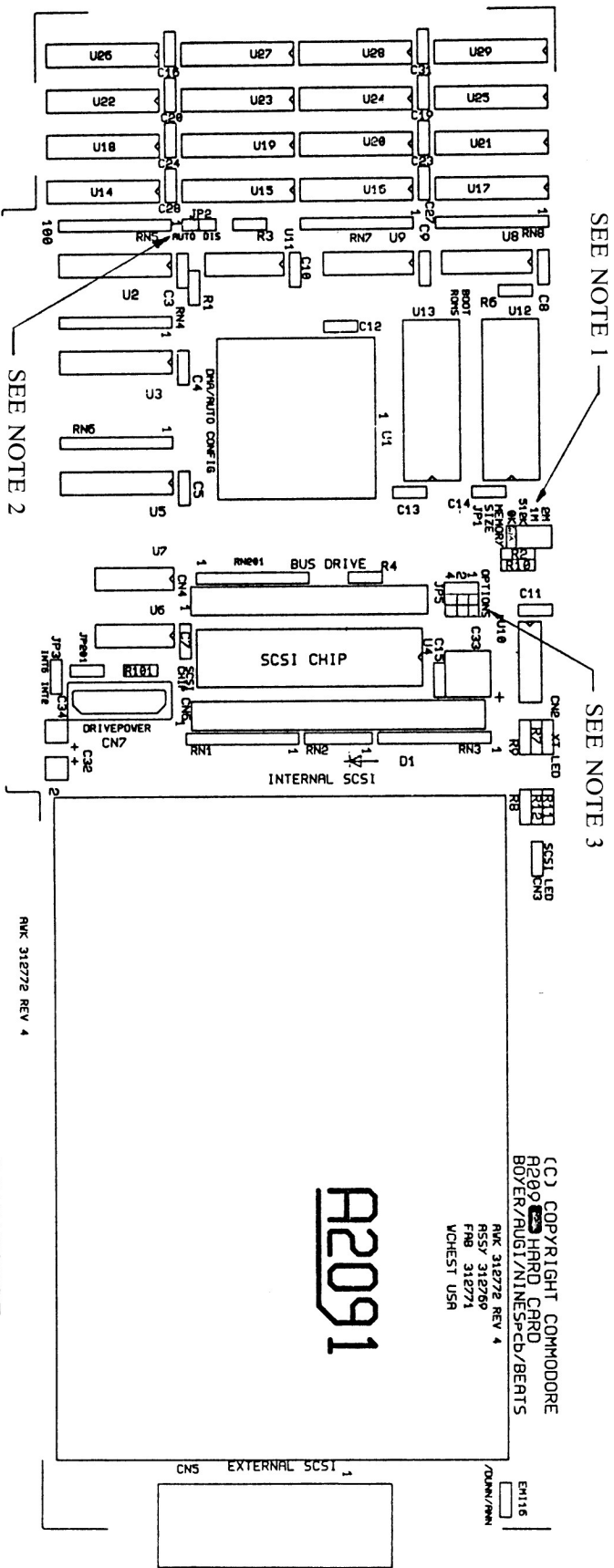

- NOTES: (UNLESS OTHERWISE SPECIFIED)**
- 1) SET ONE JUMPER ON JP1 IN "OK" POSITION.
 - 2) SET ONE JUMPER ON JP2 IN "AUTO" POSITION.
 - 3) SET THREE JUMPERS ON JP5 BUT ONLY ON 1 PIN.

PCB Assembly #314386-03

COMMODORE
A2091 HARD CARD

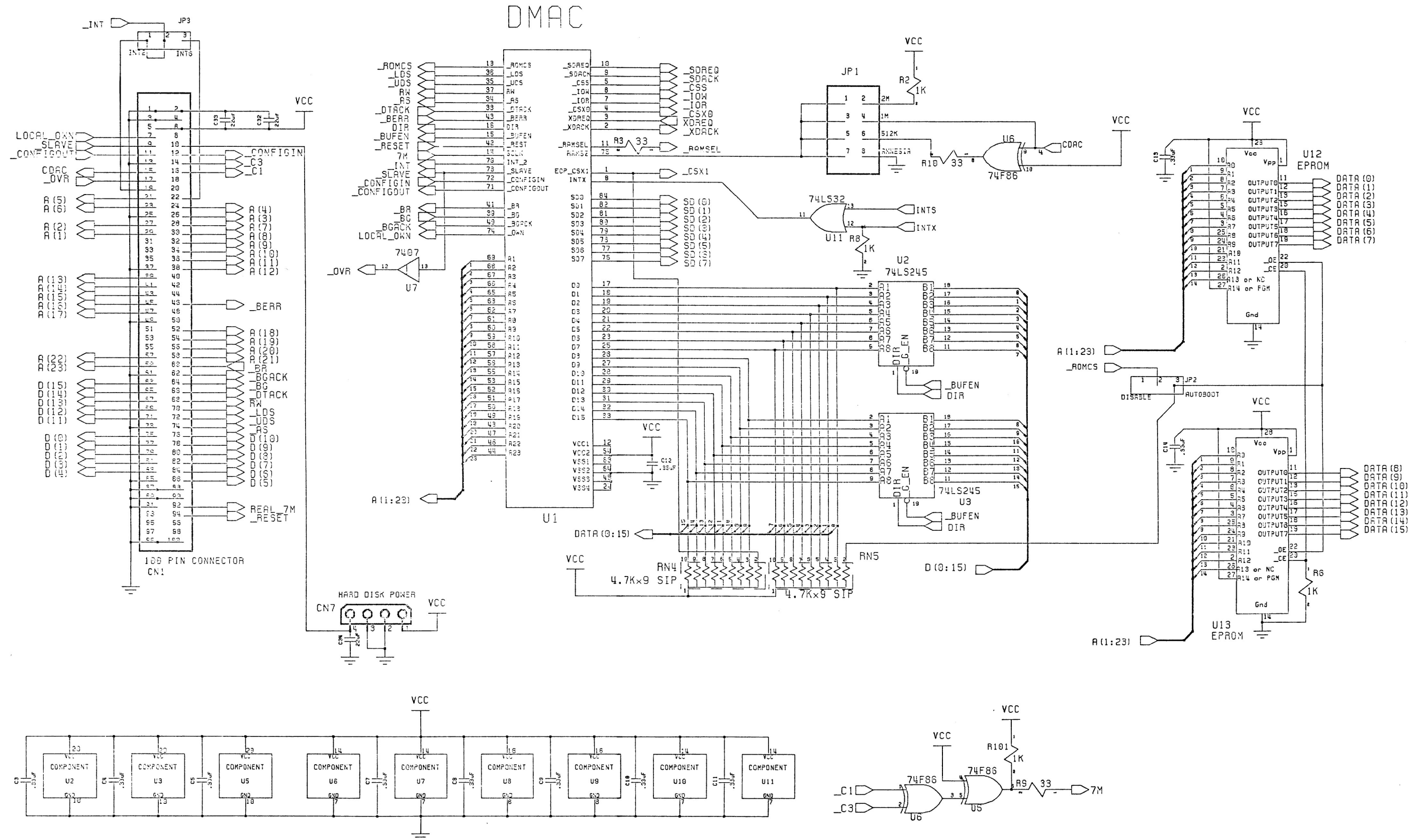

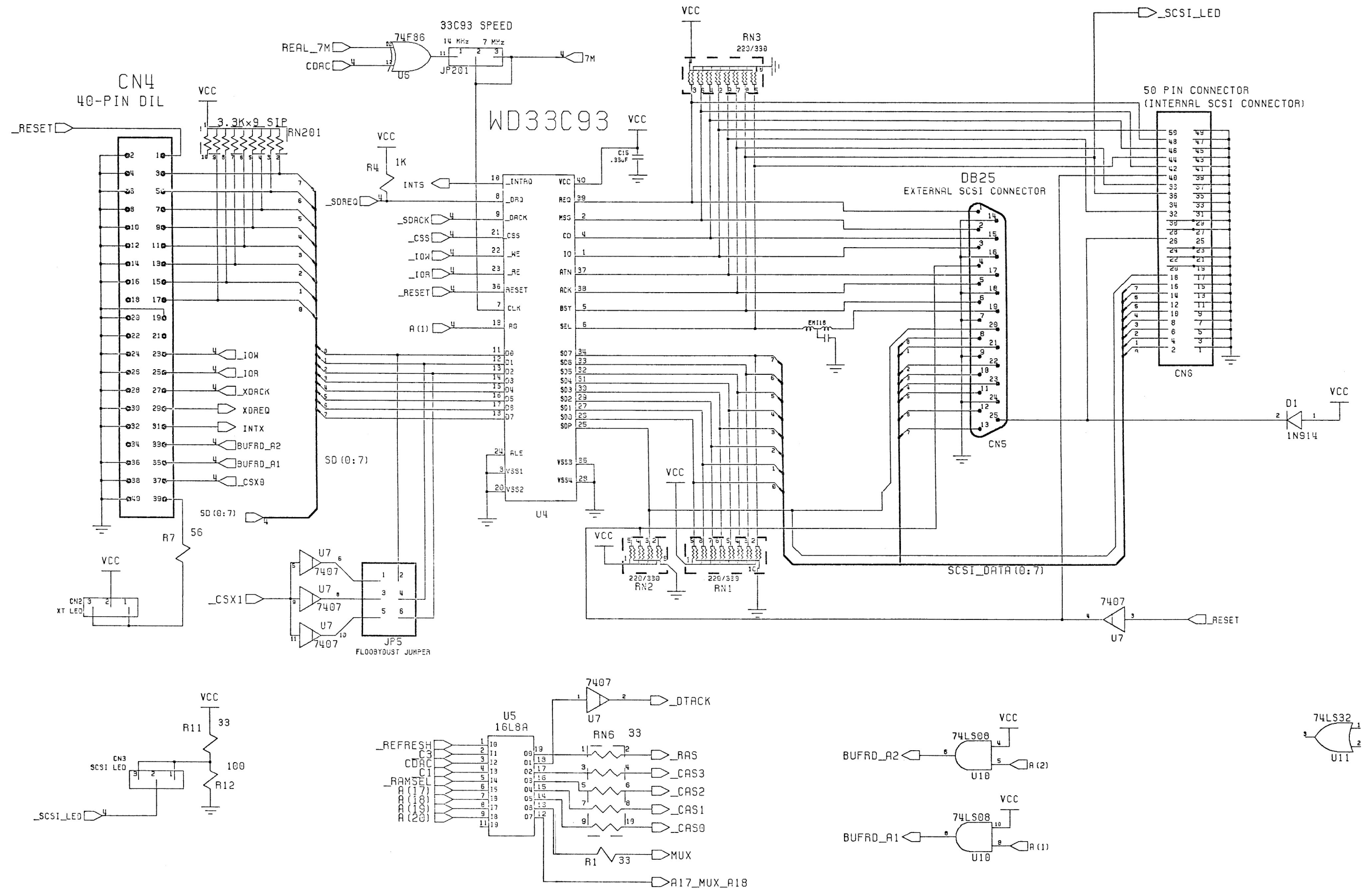

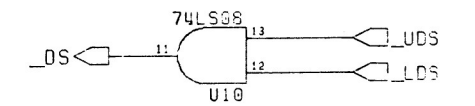
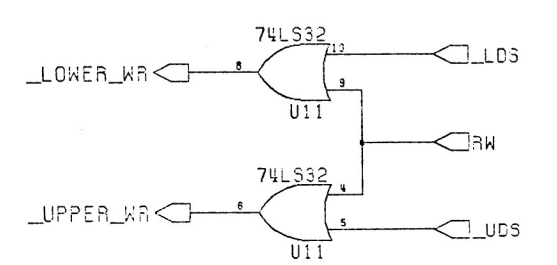
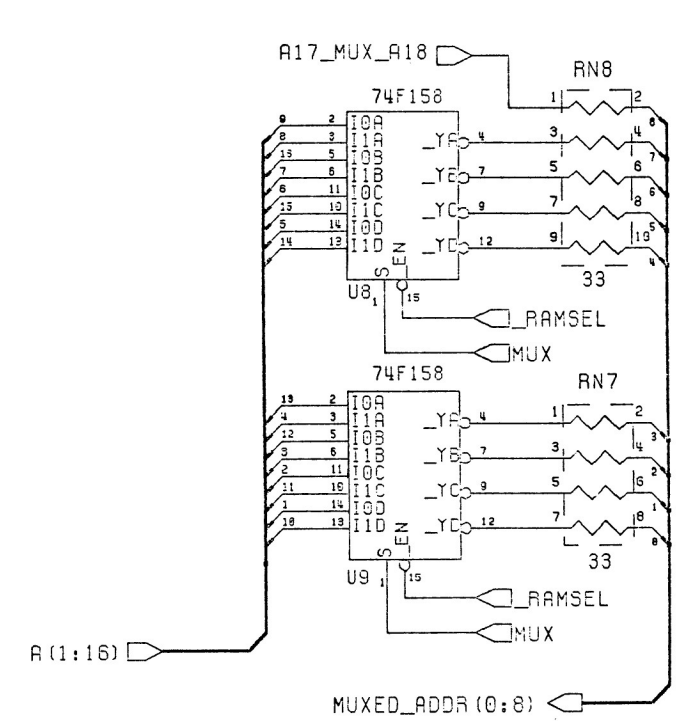
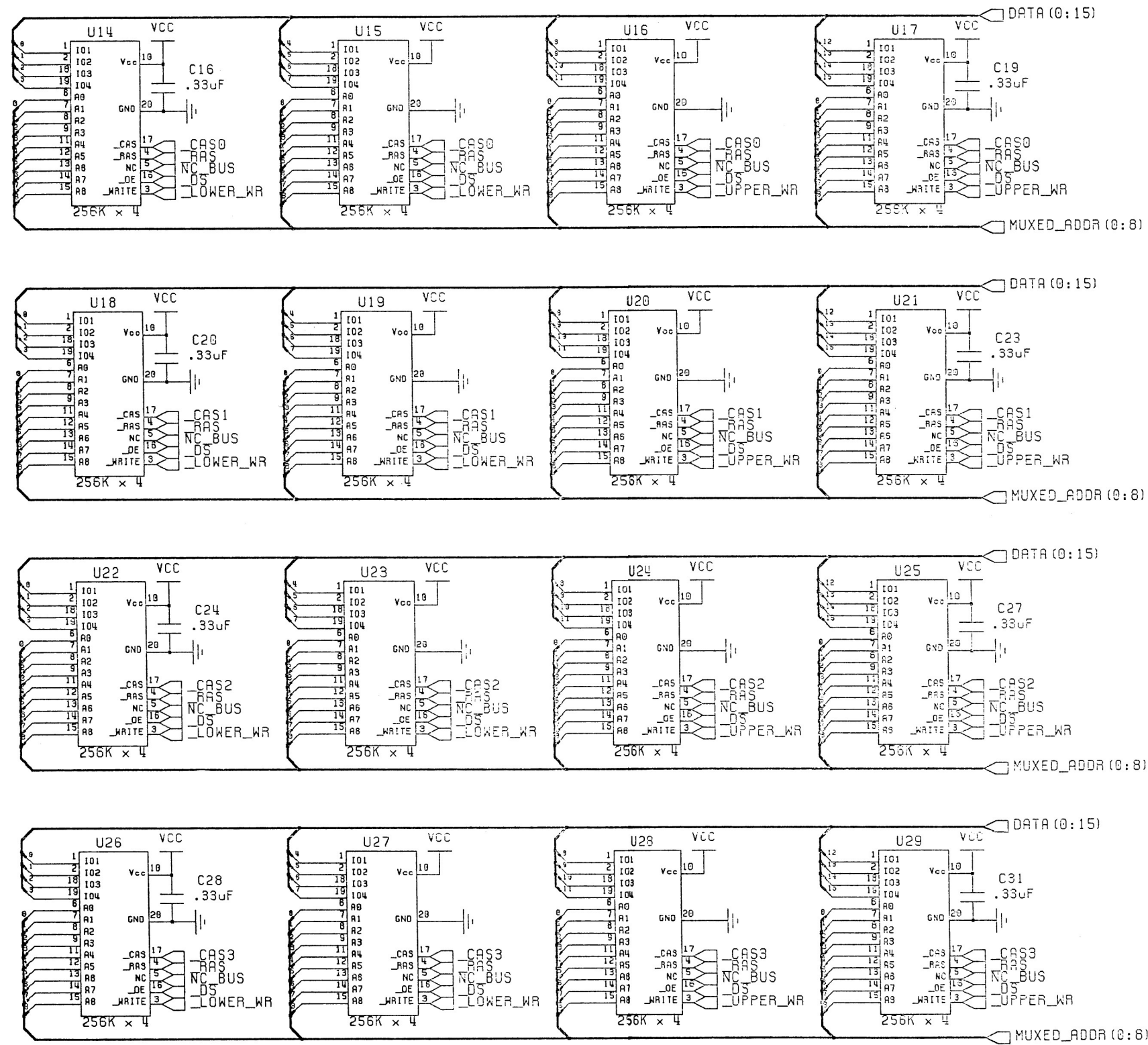

NOTE: NO CONNECT ON DRAM'S ARE CONNECTED TOGETHER TO FACILITATE FUTURE CONVERSION TO 4M PART (1M X 4)



Computer Systems Division
1200 Wilson Drive
West Chester, PA 19380