

SERVICE MANUAL

A590

AUGUST, 1989

PN-314899-01

 **Commodore**

SERVICE MANUAL

A590

AUGUST, 1989

PN-314899-01

INTERNATIONAL EDITION

COMMODORE "INTERNATIONAL EDITION" SERVICE MANUALS CONTAIN PART NUMBER INFORMATION WHICH MAY VARY ACCORDING TO COUNTRY. SOME PARTS MAY NOT BE AVAILABLE IN ALL COUNTRIES.

Commodore Business Machines, Inc.

1200 Wilson Drive, West Chester, Pennsylvania 19380 U.S.A.

Commodore makes no express or implied warranties with regard to the information contained herein. The information is made available solely on an as is basis, and the entire risk as to completeness, reliability, and accuracy is with the user. Commodore shall not be liable for any damages in connection with the use of the information contained herein. The listing of any available replacement part herein does not constitute in any case a recommendation, warranty or guaranty as to quality or suitability of such replacement part. Reproduction or use without express permission, of editorial or pictorial content, in any matter is prohibited.

This manual contains copyrighted and proprietary information. No part of this publication may be reproduced, stored in a retrieval system, or transmitted in any form or by any means, electronic, mechanical, photocopying, recording or otherwise, without the prior written permission of Commodore Electronics Limited.

Copyright © 1989 by Commodore Electronics Limited.
All rights reserved.

TABLE OF CONTENTS

SECTION 1 — SPECIFICATIONS

SECTION 2 — THEORY OF OPERATIONS

SECTION 3 — TROUBLESHOOTING GUIDE

SECTION 4 — PARTS

SECTION 5 — SCHEMATICS, CONNECTORS,
DIP SWITCHES, JUMPERS

SECTION 1
SPECIFICATIONS

A590 Specifications

Features

20 MB Hard Drive — SCSI

Expansion sockets for 2MB of fast RAM (256K x 4)

Auto-Boot ROMS

SCSI — ANSI X3T9.2 compatible

DB-25 SCSI connector

50-PIN internal SCSI connector

Host Interface — connects to 86 PIN edge connector of A500 computer.

Dimensions

6 x 10.5 x 2.75 inches, assembly

Weight

4.5 lbs, assembly

Power Requirements

117/220/240 VAC, 50 Watts (max)

SECTION 2

MEMORY OF OPERATIONS

SCSI BUS INTERFACE CONTROLLER

NOTE

PLEASE REFERENCE A590 USER MANUAL
FOR DETAILED OPERATIONS

SECTION 2

- **THEORY OF OPERATIONS**
- **SCSI BUS INTERFACE CONTROLLER**

NOTE

**PLEASE REFERENCE A590 USER MANUAL
PN-363026-01 FOR DETAILED OPERATIONS.**

Theory of Operation

The Host Power supply provided +5 volts to this Assembly through an 86-pin connector where it enables the A590 external power supply.

The Assembly as described herein shall consist of three independent subsystems:

- [1] MEMORY
- [2] DMA/SCSI CONTROLLER
- [3] AUTO-CONFIG

AUTO-CONFIG for all on-board devices (RAM, ROM, DMA controller) shall be executed by the DMA controller chip.

The DMA chip provides “__RAMSEL” and “__ROMCS” signals to indicate an access to the on board RAM and ROM, respectively. During auto-config time the DMA chip must indicate how much RAM is on board. It determines this by reading its “RAMSZ” line. The following chart shows the relationship between the signal on RAMSZ and the amount of RAM that should be present:

Signal	Amount of RAM
Ground	None
Inverse of CDAC	512K
CDAC	1M
Vcc	2M

The signal applied to “RAMSZ” is determined by JP1. The DMA controller chip also generates the signal “__SLAVE” whenever something within the auto config address space is being accessed. This is tied directly to “__OVR” to allow for generation of “__DTACK” on our board.

The auto-boot ROMS simply connect to the bus with the data outputs being enabled by “__ROMCS”. “__DTACK” is generated automatically by the DMA chip when the ROM is accessed.

The RAM section is controlled by U5. (See Timing Diagram.) U3 generates RAS and CAS for the RAMs as well as DTACK. The RAM is set up in 4 separate banks, each with its own CAS, but a common RAS. The CAS on the bank that is being accessed has a special access waveform, while the other three CAS lines will just perform a refresh. After the access, a hidden refresh is performed. If the RAM is not being accessed, all of the RAM is just continually refreshed. On writes, the byte(s) (upper, lower or both) to write shall be determined by gating and write signal to the RAMs with UDS and LDS. Byte control of reads is gated by applying LDS or UDS to the output enable inputs of the RAMs. The multiplexed address that DRAMS need is generated by U8 and U9, which is controlled by the mux signal from U5. There are two possible relationships between processor timing and the C1 and C3 clocks. U5 only understands one of these (Agnus normally synchronizes the processor to this relationship, but this relationship can be upset by DMA operations, for instance). If U5 sees the other relationship, it will insert a single wait state to realign the 68000 to what it considers correct timing. This special cycle is shown on the timing diagram in addition to normal cycles.

The DMA controller (U1) attaches to the bus and to the WD33C93 SCSI controller chip (U4). U4 attaches to an internal 50 pin SCSI connector and goes out to a DB25 connector on the back of the board which allows attachment of SCSI peripherals. The DMA controller also provides a special XT interface for IBM PC XT bus type drives (this is NOT ST-506). This connects to the internal drive. The 7-MHz clock required by the DMA controller is generated by U6. The special SCSI bus reset signal is generated whenever the Amiga is reset.

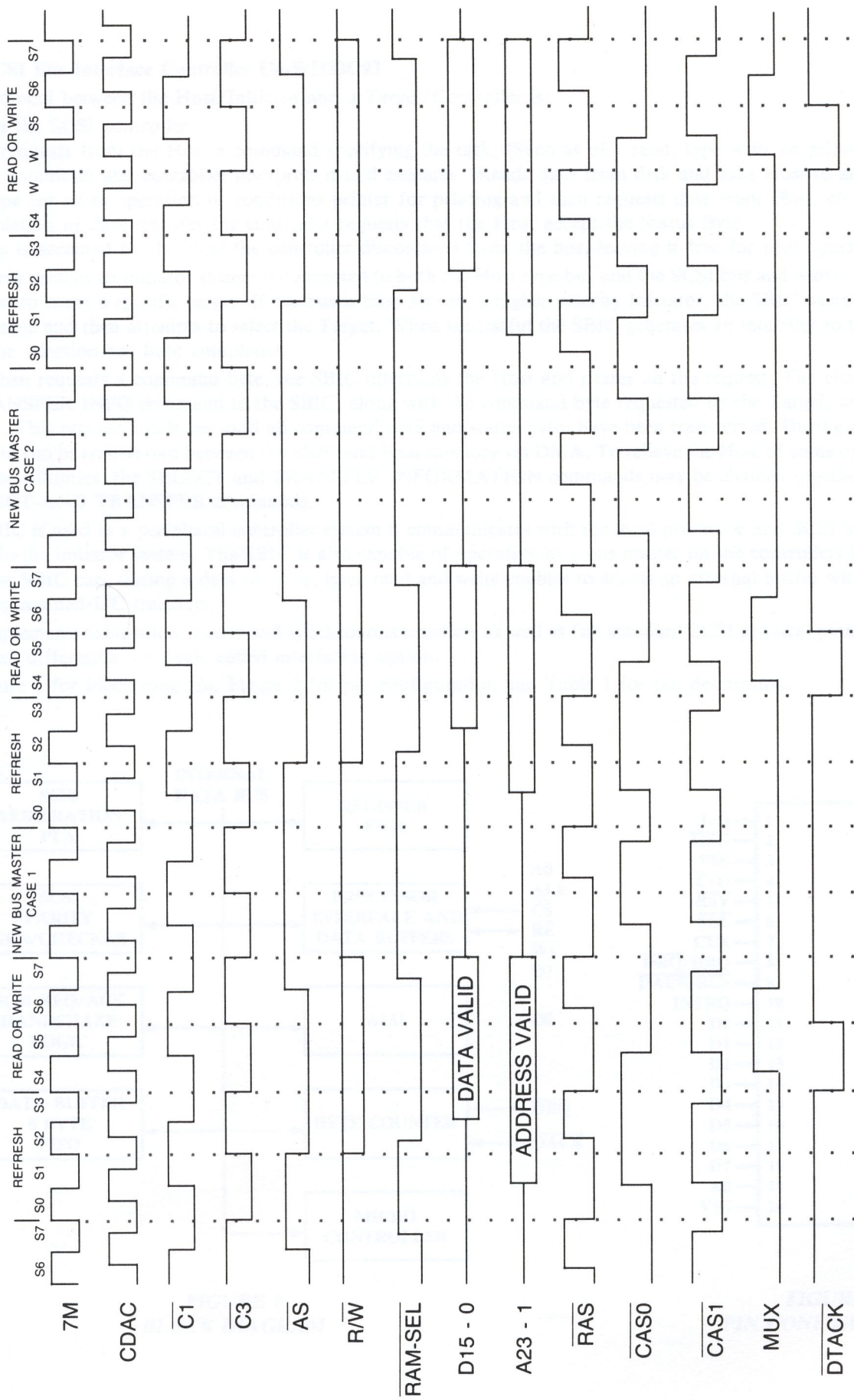

TIMING DIAGRAM

390206-01 SCSI Bus Interface Controller U4-WD33C93

The SCSI protocol between the Host/Initiator and a Target/Controller is:

- Host selects the SCSI controller
- Controller requests from the Host a command specifying the task. (Such as disk read, tape write or printer etc.)
- Host sends command and controller interprets it and executes. (Reads data from disk and asks Host to accept data, prepares tape for write operation or conditions printer for printing and then requests data from Host, etc.)
- After completion of data transfer the controller requests that the Host accept the Status Byte
- After status is accepted by the Host the controller disconnects from the bus, leaving it free for next operation

The SBIC when used in an initiator system is connected to both the Host type bus and the SCSI bus and waits for a command from the Host to select a specific target. If the bus is busy serving a higher priority Initiator, the SBIC waits for the bus to become available and then attempts to select the Target. When successful the SBIC generates an interrupt to the Host to indicate that the selection has been completed.

The Target then requests a command byte, the SBIC interrupts the Host and passes on the request. The Host responds by giving a TRANSFER INFO command to the SBIC, along with the command byte requested by the Target, and passes it on to the Target. This process continues until all command data and status bytes have been transferred. During a data transfer phase, the data can be transferred between the SBIC and Host memory via DMA. To relieve the Host of some of the interrupt-handling responsibilities, the SELECT and TRANSFER INFORMATION commands may be chained together by using the special SELECT-AND TRANSFER commands.

When the SBIC is used in a peripheral controller system it communicates with the local processor and SCSI bus in the same way as used in the initiator system. The SBIC is also capable of operating as a bus master on the controllers local data bus. Therefore, the SBIC can, during a data transfer, issue read and write enables to access an external buffer without requiring DMA or programmed I/C transfers.

The SBIC implements arbitration, parity and synchronous transfers as well as full standard SCSI physical path definition for use with either differential or single ended interfacing option.

Refer to Figure 1 for block diagram, Figure 2 for pin configuration and Table 1 for pin description.

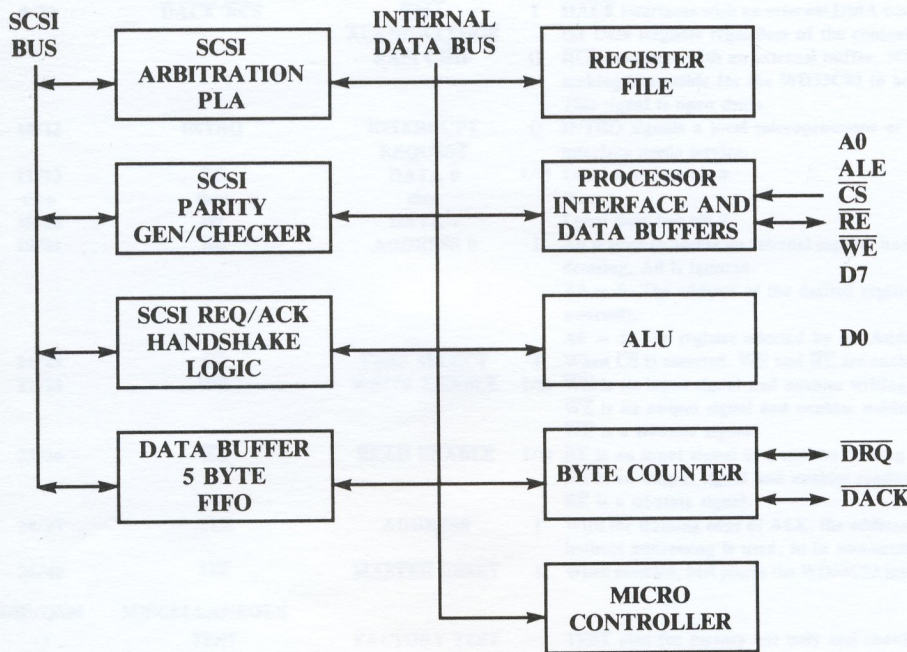

**FIGURE 1
BLOCK DIAGRAM**

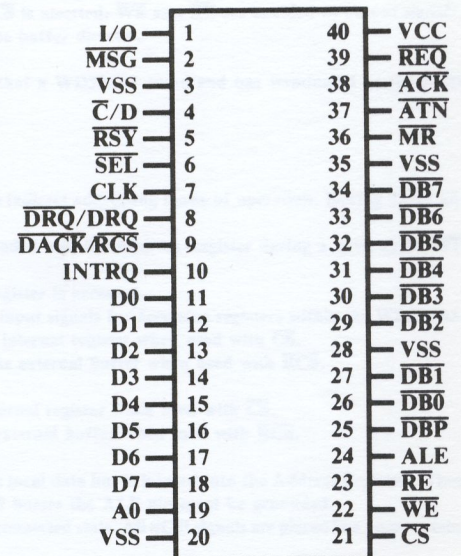

**FIGURE 2
PIN CONFIGURATION**

TABLE 1

PIN NUMBER	MNEMONIC	SIGNAL NAME	I/O	FUNCTION
SCSI INTERFACE — ALL SCSI pins have open-drain output drivers				
DIP/QSM 1/2	I/O	INPUT/OUTPUT	I/O	I/O controls the direction of data movement on the SCSI bus with respect to the Initiator. When asserted, data is input to the Initiator. When de-asserted, data is output from the Initiator. IO is an input signal when the WD33C93 is operating as an Initiator and an output signal when operating as a Target.
2/3	MSG	MESSAGE	I/O	MSG is asserted during a message phase. MSG is an input when the WD33C93 is operating as an Initiator and an output when operating as a Target.
4/5	C/D	CONTROL/DATA	I/O	C/D is asserted when there is Control information on the SCSI data bus and de-asserted for data. C/D is an input when the WD33C93 is operating as an Initiator and an output when operating as a Target.
5/6	BSY	BUSY	I/O	BSY is asserted by the WD33C93 as an output when attempting to arbitrate for the SCSI bus or when connected as a target. When the WD33C93 is connected as an Initiator, BSY operates as an input.
6/7	SEL	SELECT	I/O	The WD33C93 asserts SEL as an output when trying to select or reselect another SCSI device. The WD33C93 receives SEL as an input when it is being selected.
25/28	DBP	SCSI DATA PARITY	I/O	SCSI bus data parity.
26/29	DB0	SCSI DATA 0	I/O	SCSI bus data bit 0.
27/30	DB1	SCSI DATA 1	I/O	SCSI bus data bit 1.
29/32	DB2	SCSI DATA 2	I/O	SCSI bus data bit 2.
thru	thru	thru	thru	
32/35	DB5	SCSI DATA 5	I/O	SCSI bus data 5.
33/37	DB6	SCSI DATA 6	I/O	SCSI bus data bit 6.
34/38	DB7	SCSI DATA 7	I/O	SCSI bus data bit 7.
37/41	ATN	ATTENTION	I/O	ATN signals that the Initiator has a message to transfer. ATN is an output signal when the WD33C93-SBIC is operating as an Initiator and an input signal when connected as a Target.
38/42	ACK	ACKNOWLEDGE	I/O	ACK acknowledges a REQ/ACK data transfer handshake. ACK is an output signal when the WD33C93 is operating as an Initiator and an input when operating as a Target.
39/43	REQ	REQUEST	I/O	REQ requests an REQ/ACK data transfer REQ is an input signal when the WD33C93 is operating as an Initiator and an output signal when operating as a Target.
PROCESSOR/DMA INTERFACE				
7/8	CLK	CLOCK	I	10 MHz square wave clock.
8/9	DRQ/DRQ	DATA REQUEST	O	DRQ interfaces with an external DMA controller (eq. 8237) and forms the DRQ/DACK handshake for data byte transfers.
		DATA REQUEST	I	DRQ interfaces with an external buffer. When asserted, data burst transfers are enabled using Direct Buffer Access (DBA). This signal is open drain.
9/10	DACK/RCS	DMA ACKNOWLEDGE RAM CHIP	I	DACK interfaces with an external DMA controller (eg. 8347). When asserted, all bus transfers are to or from the Data Register regardless of the contents of the Address Register.
			O	RCS interfaces with an external buffer. When RCS is asserted, WE and RE are enabled as output signals, making it possible for the WD33C93 to access the buffer directly. This signal is open drain.
10/12	INTRQ	INTERRUPT REQUEST	O	INTRQ signals a local microprocessor or Host that a WD33C93 command has terminated or the SCSI interface needs service.
11/13	D0	DATA 0	I/O	Local data bus bit 0.
thru	thru	thru	thru	
18/20	D7	DATA 7		Local data bus bit 7.
19/21	A0	ADDRESS 0	I	A0 is used to access an internal register during the indirect addressing mode of operation. During direct addressing, A0 is ignored. A0 = 0. The address of the desired register is loaded into the Address Register during a write cycle (WE asserted). A0 = 1. The register selected by the Address Register is accessed.
21/24	CS	CHIP SELECT	I	When CS is asserted, WE and RE are enabled as input signals for accessing registers within the WD33C93.
22/25	WE	WRITE ENABLE	I/O	WE is an input signal and enables writing to an internal register when used with CS. WE is an output signal and enables writing to the external buffer when used with RCS. WE is a tri-state signal.
23/26	RE	READ ENABLE	I/O	RE is an input signal and enables reading an internal register when used with CS. RE is an output signal and enables reading the external buffer when used with RCS. RE is a tri-state signal.
24/27	ALE	ADDRESS	I	With the training edge of ALE, the address on the local data bus is latched into the Address Register. When indirect addressing is used, as in non-multiplexed busses the ALE pin must be grounded.
26/40	MR	MASTER RESET	I	When asserted, MR places the WD33C93 into a disconnected state. All SCSI signals are placed in a passive state.
MISCELLANEOUS				
DIP/QSM /1	TEST	FACTORY TEST		TEST pins for factory use only and should not be connected.
/11	TEST	FACTORY TEST		
3/4	VSS	GROUND		
20/33	VSS	GROUND		
28/41	VSS	GROUND		
35/39	VSS	GROUND		
49	TEST	FACTORY TEST		
/36	TEST	FACTORY TEST		
40/+4	VCC	+5 VOLTS		

SECTION 3

- **TROUBLESHOOTING GUIDE**
- **INSTALLING DRAMS**

TROUBLESHOOTING

With the power off, make sure that all cables are connected correctly, and that the A590 is properly connected to the Amiga.

SYMPTOM	CAUSE	SOLUTION
Power light is not on.	Power supply not plugged into wall. Power supply not plugged into A590. A500 power supply not turned on.	Check connections to wall and A590.
A500 power light blinks, or system fails with the A590 connected.	A500 is running with Kickstart 1.2 and DIP switch 1 is set to autoboot enabled.	Set DIP switch 1 to OFF.
System cannot find the A590.	A500 is running Kickstart 1.3 and DIP switch is set to autoboot disabled.	Set DIP switch 1 to ON.
System cannot find the A590.	A500 is running Kickstart 1.2 and the device driver was not copied to expansion drawer.	Boot with disk created with MakeBootDisk.
Not a DOS disk in Unit 1. Unit appears as NDOS on Workbench screen.	Hard drive Prepped but not formatted.	Format the hard disk from CLI/Shell or initialize hard disk from Workbench.
Read/Write error.	Bad block on hard drive.	Run Verify Data on Drive from HDToolbox. For more information refer to the section Backing Up Your Hard Disk.
During format system reports Can't find handler.	System not using most recent Fast File System from the A590 Setup disk.	Copy Fast File System from the L directory on the A590 Setup disk to your boot disk.
You have an external Seagate drive attached and when you boot from the A590 the system displays the Workbench request.	If you can reboot the system and it functions normally after reboot, the time-out is too short.	Set DIP switch 3 to the on position.
An external hard disk appears multiple times on the screen.	The hard disk responds to all logical addresses.	Set DIP switch 2 to the off position.
When you attempt to access the hard disk, the hard disk light turns on and stays on, but the system locks up and permits no further actions.	Drive does not generate a standard parity signal.	Set DIP switch 3 to the on position.

INSTALLING RANDOM ACCESS MEMORY (RAM) CHIPS

You can install RAM chips in the A590 to increase the memory available to your Amiga 500. You can install 512KB, 1MB or 2MB of additional memory.

Note: Use only CMOS 256k x 4 DRAMs, with an access speed of 120 ns or faster. Slower DRAMs will not work properly. Do not use NMOS DRAMs. The use of NMOS DRAMs will damage the A590 and void your warranty.

RAM chips are sensitive to static electricity. Contact with a chip when high levels of static electricity are present could ruin a chip. Touching a nearby grounded metal surface before touching the chip can help reduce static levels.

Installation of RAM chips should be performed by an authorized Commodore Service Center, or by your Commodore dealer. Commodore will not be responsible or liable for any damages caused by improper installation of RAM chips.

APPROVED VENDORS

100 NS	NEC UPD424256C-10
	MATSUSHITA MN414256-10
120 NS	TOSHIBA TC514256P-12
	FUJITSU MB81C4256-12P

Note: Commodore will stock 256k x DRAMs, availability will be announced in Techttopics parts section.

WARNING: If your A590 is connected to the computer, you must first turn off the power, disconnect all cables and peripherals, and detach the A590 from the computer by carefully pulling the A590 directly away from the A500.

The following steps, required to install RAM chips, are explained in detail below:

1. Remove the A590's cover.
2. Remove the drive and the drive shield.
3. Insert the RAM chips.
4. Set the RAM size jumper.
5. Replace the drive and the cover.

1. Removing the A590's cover.

Locate the two screws on the connector side of the A590. Loosen these screws, but do not remove them.

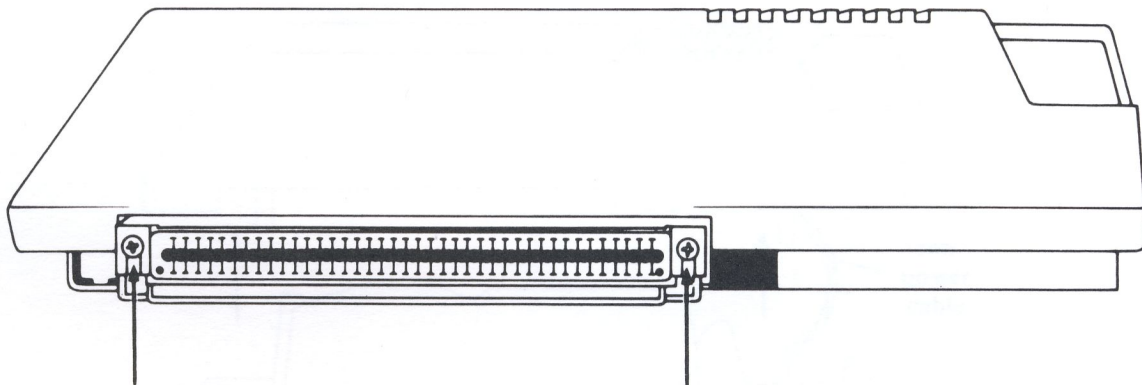

Locate the eight screws on the bottom of the A590. The outer four connect the cover to the base and the inner four connect the drive and the drive shield to the base. Remove the outer four and set these screws aside.

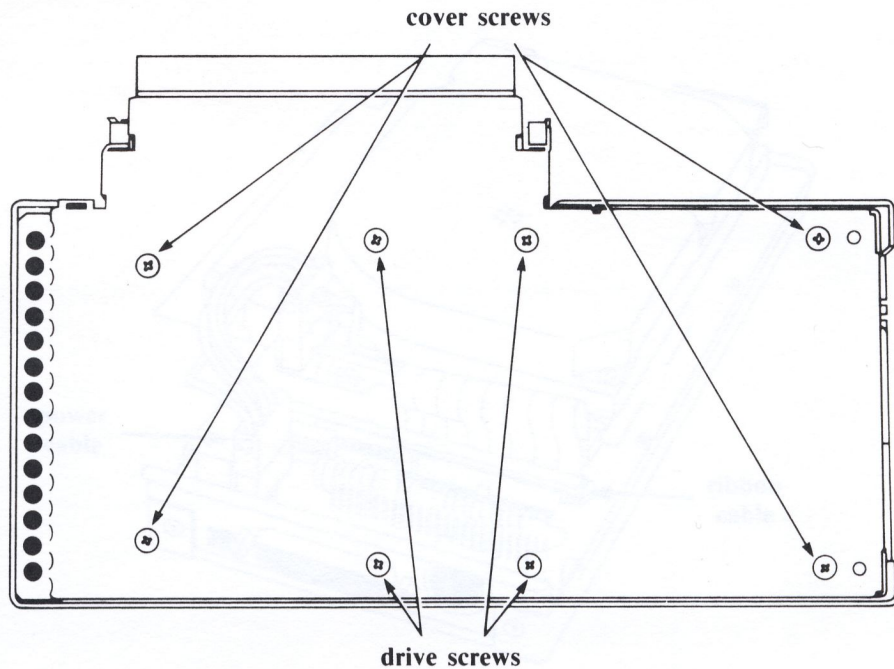

Place the A590 on a flat surface and carefully lift the cover straight off. Disconnect the fan power cable from the printed circuit board in the base of the A590. Note the alignment of the LED cable if there is one, so that it can be reconnected properly. Disconnect the LED cable and put the cover aside.

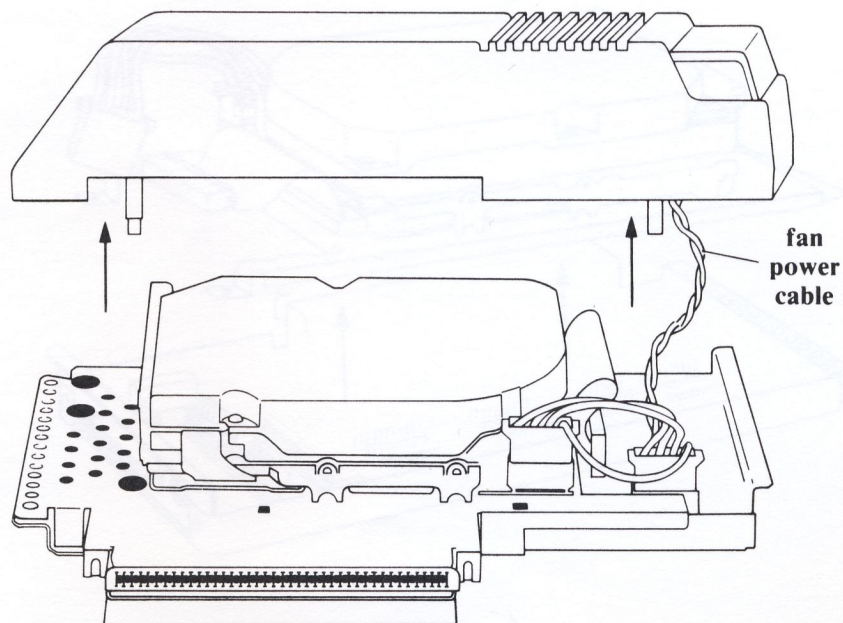

2. Removing the drive and the drive shield.

Locate the ribbon cable connector and the power cable connector and note how they connect to the board, so you can reconnect them properly. Disconnect them from where they attach to the board. Always handle each cable by the plastic connector.

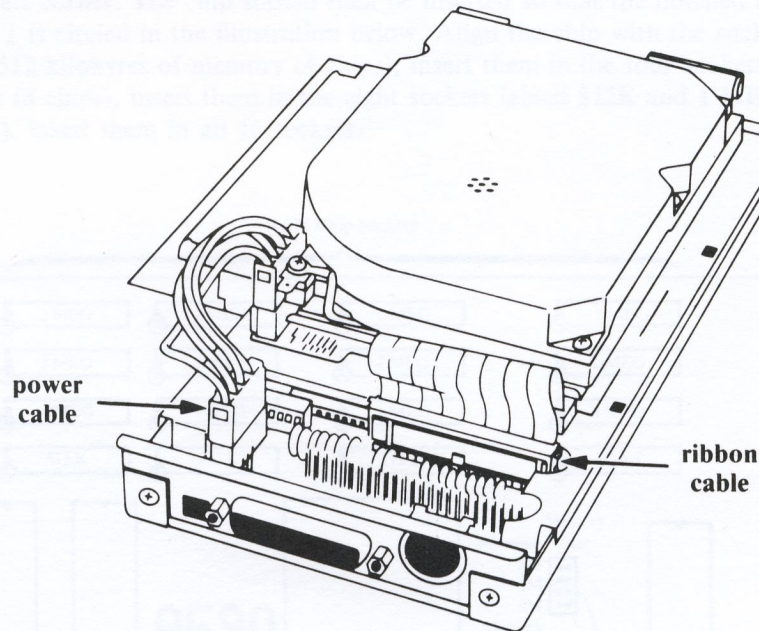

Remove the four remaining screws, and put them aside, separate from the first four screws. Lift the drive and shield off and put them aside in a safe place. Place the drive on a soft, non-conductive surface. **Do not subject the drive to shock.**

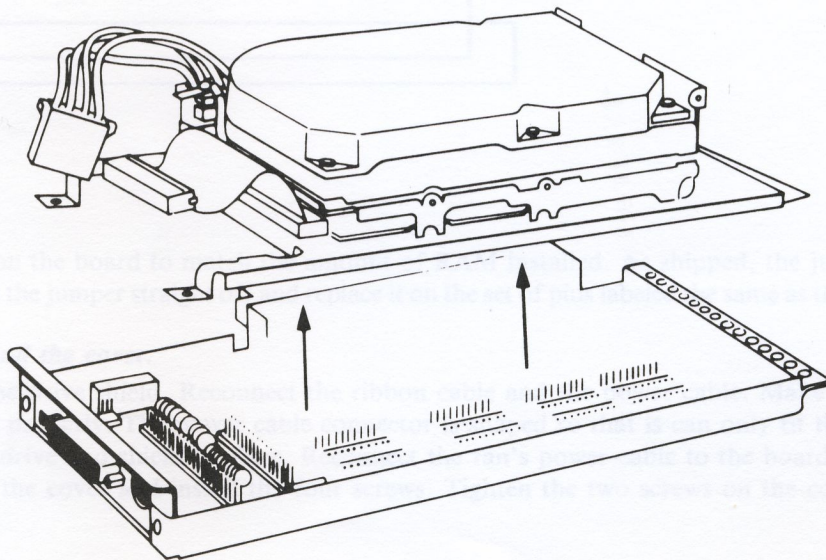

3. Inserting the RAM chips.

Note: Be careful to properly align the chips before inserting them. Do not force them or bend the pins.

Turn the A590's board so that it matches the illustration below. It is important that the chips be inserted properly. Each chip has a notch or dot on one end to show the location of pin 1. When the end with the notch or dot is held to the left, pin 1 will be in the lower left corner. The chip should then be inserted so that the notched end is towards the left of the board. The location for pin 1 is circled in the illustration below. Align the chip with the socket and insert it with slight pressure. If you are installing 512 kilobytes of memory (4 chips), insert them in the four sockets labeled **512K**. If you are installing 1 megabyte of memory (8 chips), insert them in the eight sockets labeled **512K** and **1 MEG**. If you are installing 2 megabytes of memory (16 chips), insert them in all 16 sockets.

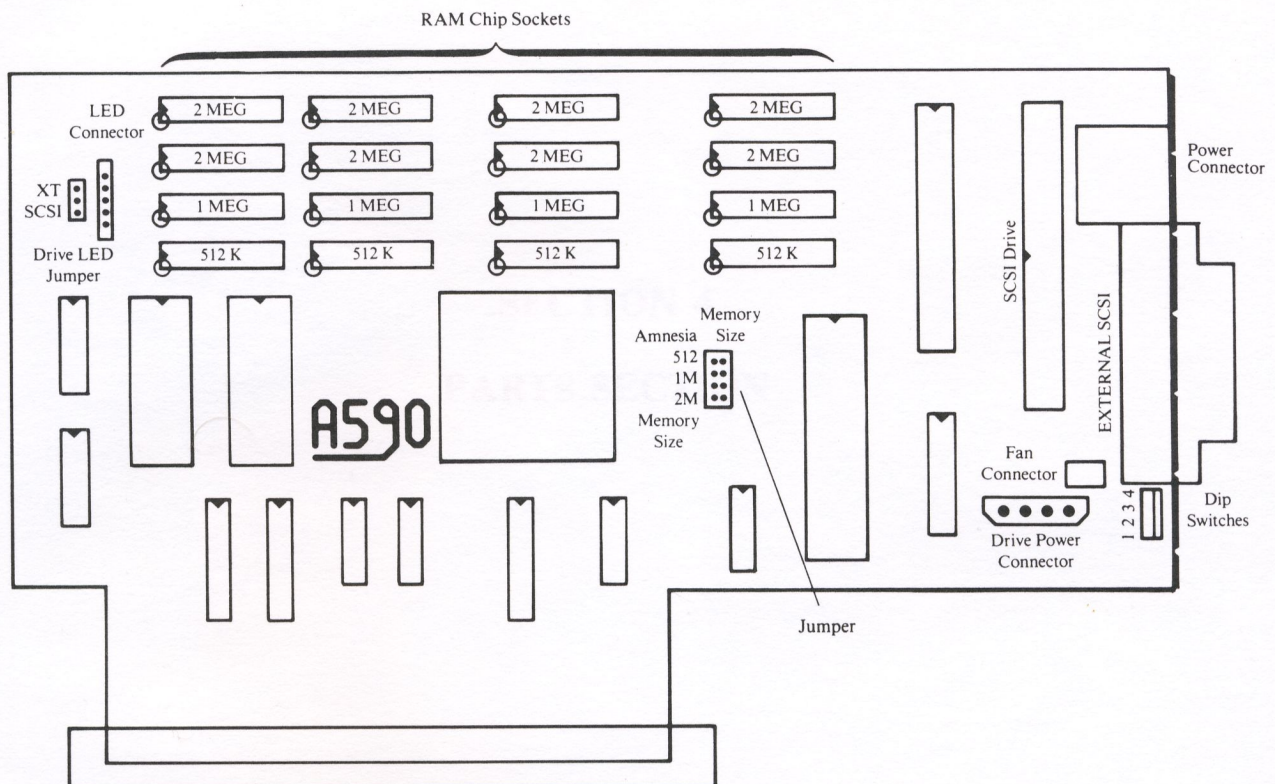

4. Setting the jumper.

You must set a jumper on the board to match the amount of RAM installed. As shipped, the jumper is set to "Amnesia", or no RAM installed. Lift the jumper straight off and replace it on the set of pins labeled the same as the amount of RAM installed.

5. Replacing the drive and the cover.

Replace the drive and the drive shield. Reconnect the ribbon cable and the power cable. Make certain that the connectors and the pins are aligned properly. The power cable connector is shaped so that it can only fit the correct way. Replace the four screws to hold the drive and shield in place. Reconnect the fan's power cable to the board. Reconnect the LED cable if there is one. Replace the cover and install the four screws. Tighten the two screws on the connector side of the A590.

SECTION 4
PARTS SECTION

A590 HDD INTERNATIONAL SHIPPING ASSEMBLIES (312641)

312641-01 SHIPPING ASSY A590 SCSI (US)

363146-01 SHIPPING BOX A590
363147-01 PROTECTION SHEET, SIDE
363148-01 PROTECTION SHEET TOP & BOTTOM
312642-01 PACKING ASSY (US)

312641-02 SHIPPING ASSY A590 SCSI (CANADA)

363146-01 SHIPPING BOX A590
363147-01 PROTECTION SHEET, SIDE
363148-01 PROTECTION SHEET TOP & BOTTOM
312642-02 PACKING ASSY (CANADA)

312641-03 SHIPPING ASSY A590 SCSI (AUSTRALIA)

363146-01 SHIPPING BOX A590
363147-01 PROTECTION SHEET, SIDE
363148-01 PROTECTION SHEET TOP & BOTTOM
312642-03 PACKING ASSY (AUSTRALIA)

312641-04 SHIPPING ASSY A590 SCSI (UK)

363146-01 SHIPPING BOX A590
363147-01 PROTECTION SHEET, SIDE
363148-01 PROTECTION SHEET TOP & BOTTOM
312642-04 PACKING ASSY (UK)

312641-05 SHIPPING ASSY A590 SCSI (ITALY)

363146-01 SHIPPING BOX A590
363147-01 PROTECTION SHEET, SIDE
363148-01 PROTECTION SHEET TOP & BOTTOM
312642-05 PACKING ASSY (ITALY)

312641-06 SHIPPING ASSY A590 SCSI (SPAIN)

363146-01 SHIPPING BOX A590
363147-01 PROTECTION SHEET, SIDE
363148-01 PROTECTION SHEET TOP & BOTTOM
312642-06 PACKING ASSY (SPAIN)

**312641-07 SHIPPING ASSY A590 SCSI
(SWITZERLAND)**

363146-01 SHIPPING BOX A590
363147-01 PROTECTION SHEET, SIDE
363148-01 PROTECTION SHEET TOP & BOTTOM
312642-07 PACKING ASSY (SWITZERLAND)

312641-08 SHIPPING ASSY A590 SCSI (GERMANY)

363146-01 SHIPPING BOX A590
363147-01 PROTECTION SHEET, SIDE
363148-01 PROTECTION SHEET TOP & BOTTOM
312642-07 PACKING ASSY (GERMANY)

312641-09 SHIPPING ASSY A590 SCSI (FRANCE)

363146-01 SHIPPING BOX A590
363147-01 PROTECTION SHEET, SIDE
363148-01 PROTECTION SHEET TOP & BOTTOM
312642-07 PACKING ASSY (FRANCE)

**312641-10 SHIPPING ASSY A590 SCSI
(NETHERLANDS)**

363146-01 SHIPPING BOX A590
363147-01 PROTECTION SHEET, SIDE
363148-01 PROTECTION SHEET TOP & BOTTOM
312642-07 PACKING ASSY (NETHERLANDS)

312641-11 SHIPPING ASSY A590 SCSI (SWEDEN)

363146-01 SHIPPING BOX A590
363147-01 PROTECTION SHEET, SIDE
363148-01 PROTECTION SHEET TOP & BOTTOM
312642-07 PACKING ASSY (SWEDEN)

312641-12 SHIPPING ASSY A590 SCSI (DENMARK)

363146-01 SHIPPING BOX A590
363147-01 PROTECTION SHEET, SIDE
363148-01 PROTECTION SHEET TOP & BOTTOM
312642-07 PACKING ASSY (DENMARK)

312641-13 SHIPPING ASSY A590 SCSI (NORWAY)

363146-01 SHIPPING BOX A590
363147-01 PROTECTION SHEET, SIDE
363148-01 PROTECTION SHEET TOP & BOTTOM
312642-07 PACKING ASSY (NORWAY)

A590 HDD INTERNATIONAL PACKING ASSEMBLIES (312642)

312642-01 PACKING ASSY A590 HDD (US)

- 312643-01 MAIN ASSY A590 SCSI
- 312643-02 MAIN ASSY SUB: 312643-01
- 363143-01 INDIVIDUAL PACKING BOX (EFIGS)
- 318202-01 TOP FOAM
- 318203-01 BOTTOM FOAM
- 316645-01 UPC LABEL (US)
- 312639-01 POWER SUPPLY - UL/CSA
- 318904-01 WARRANTY CARD - US 90 DAYS
- 314877-02 SERVICE CENTER LIST (US ONLY)
- 363026-01 USER MANUAL - EFIGS
- 312568-01 EXPANSION PORT GROUND CLIP
- 318896-01 SOFTWARE LICENSE AGREEMENT (US, CANADA, AUSTRALIA)
- 312341-01 DISKETTE REPLACEMENT CARD (US)
- 251006-05 ANTI-STATIC BAG

312642-02 PACKING ASSY A590 HDD (CANADA)

- 312643-01 MAIN ASSY A590 SCSI
- 312643-02 MAIN ASSY SUB: 312643-01
- 363143-01 INDIVIDUAL PACKING BOX (EFIGS)
- 318202-01 TOP FOAM
- 318203-01 BOTTOM FOAM
- 312639-01 POWER SUPPLY - UL/CSA
- 318882-01 WARRANTY REGISTRATION - CANADA
- 363026-01 USER MANUAL - EFIGS
- 312568-01 EXPANSION PORT GROUND CLIP
- 318896-01 SOFTWARE LICENSE AGREEMENT (US, CANADA, AUSTRALIA)
- 318556-02 DISKETTE REPLACEMENT CARD (CANADA)
- 251006-05 ANTI-STATIC BAG

312642-03 PACKING ASSY A590 HDD (AUSTRALIA)

- 312643-01 MAIN ASSY A590 SCSI
- 312643-02 MAIN ASSY SUB: 312643-01
- 363143-01 INDIVIDUAL PACKING BOX (EFIGS)
- 318202-01 TOP FOAM
- 318203-01 BOTTOM FOAM
- 312639-05 POWER SUPPLY - SAA
- 318884-01 WARRANTY CARD - AUSTRALIA
- 363026-01 USER MANUAL - EFIGS
- 312568-01 EXPANSION PORT GROUND CLIP
- 318896-01 SOFTWARE LICENSE AGREEMENT (US, CANADA, AUSTRALIA)
- 251006-05 ANTI-STATIC BAG

312642-04 PACKING ASSY A590 HDD (UK)

- 312643-01 MAIN ASSY A590 SCSI
- 312643-02 MAIN ASSY SUB: 312643-01
- 363143-01 INDIVIDUAL PACKING BOX (EFIGS)
- 318202-01 TOP FOAM
- 318203-01 BOTTOM FOAM
- 312639-02 POWER SUPPLY - BSI
- 363026-01 USER MANUAL - EFIGS
- 312568-01 EXPANSION PORT GROUND CLIP
- 251006-05 ANTI-STATIC BAG

312642-05 PACKING ASSY A590 HDD (ITALY)

- 312643-01 MAIN ASSY A590 SCSI
- 312643-02 MAIN ASSY SUB: 312643-01
- 363143-01 INDIVIDUAL PACKING BOX (EFIGS)
- 318202-01 TOP FOAM
- 318203-01 BOTTOM FOAM
- 312639-03 POWER SUPPLY - VDE
- 363026-01 USER MANUAL - ITALY
- 312568-01 EXPANSION PORT GROUND CLIP
- 251006-05 ANTI-STATIC BAG

312642-06 PACKING ASSY A590 HDD (SPAIN)

- 312643-01 MAIN ASSY A590 SCSI
- 312643-02 MAIN ASSY SUB: 312643-01
- 363143-01 INDIVIDUAL PACKING BOX (EFIGS)
- 318202-01 TOP FOAM
- 318203-01 BOTTOM FOAM
- 312639-03 POWER SUPPLY - VDE
- 363026-02 USER MANUAL - SPANISH
- 312568-01 EXPANSION PORT GROUND CLIP
- 251006-05 ANTI-STATIC BAG

312642-07 PACKING ASSY A590 HDD (SWITZERLAND)

- 312643-01 MAIN ASSY A590 SCSI
- 312643-02 MAIN ASSY SUB: 312643-01
- 363143-01 INDIVIDUAL PACKING BOX (EFIGS)
- 318202-01 TOP FOAM
- 318203-01 BOTTOM FOAM
- 312639-04 POWER SUPPLY - SEV
- 363026-01 USER MANUAL - GERMAN
- 380933-01 WARRANTY CARD (SWITZERLAND)
- 312568-01 EXPANSION PORT GROUND CLIP
- 251006-05 ANTI-STATIC BAG

A590 HDD INTERNATIONAL PACKING ASSEMBLIES (312642) (continued)

312642-08 PACKING ASSY A590 HDD (GERMANY)

312643-01 MAIN ASSY A590 SCSI
 312643-02 MAIN ASSY SUB: 312643-01
 363143-01 INDIVIDUAL PACKING BOX (EFIGS)
 318202-01 TOP FOAM
 318203-01 BOTTOM FOAM
 312639-03 POWER SUPPLY - VDE
 363211-01 USER MANUAL - GERMAN
 320046-06 WARRANTY CARD (GERMANY)
 312568-01 EXPANSION PORT GROUND CLIP
 251006-05 ANTI-STATIC BAG

312642-09 PACKING ASSY A590 HDD (FRANCE)

312643-01 MAIN ASSY A590 SCSI
 312643-02 MAIN ASSY SUB: 312643-01
 363143-01 INDIVIDUAL PACKING BOX (EFIGS)
 318202-01 TOP FOAM
 318203-01 BOTTOM FOAM
 312639-03 POWER SUPPLY - VDE
 363027-01 USER MANUAL - FRENCH
 325254-01 WARRANTY CARD (FRANCE)
 312568-01 EXPANSION PORT GROUND CLIP
 251006-05 ANTI-STATIC BAG

**312642-10 PACKING ASSY A590 HDD
(NETHERLANDS)**

312643-01 MAIN ASSY A590 SCSI
 312643-02 MAIN ASSY SUB: 312643-01
 363143-01 INDIVIDUAL PACKING BOX (EFIGS)
 318202-01 TOP FOAM
 318203-01 BOTTOM FOAM
 312639-03 POWER SUPPLY - VDE
 363213-01 USER MANUAL - DUTCH
 312568-01 EXPANSION PORT GROUND CLIP
 251006-05 ANTI-STATIC BAG

312642-11 PACKING ASSY A590 HDD (SWEDEN)

312643-01 MAIN ASSY A590 SCSI
 312643-02 MAIN ASSY SUB: 312643-01
 363143-01 INDIVIDUAL PACKING BOX (EFIGS)
 318202-01 TOP FOAM
 318203-01 BOTTOM FOAM
 312639-03 POWER SUPPLY - VDE
 363214-01 USER MANUAL - SWEDISH
 312568-01 EXPANSION PORT GROUND CLIP
 251006-05 ANTI-STATIC BAG

312642-12 PACKING ASSY A590 HDD (DENMARK)

312643-01 MAIN ASSY A590 SCSI
 312643-02 MAIN ASSY SUB: 312643-01
 363143-01 INDIVIDUAL PACKING BOX (EFIGS)
 318202-01 TOP FOAM
 318203-01 BOTTOM FOAM
 312639-03 POWER SUPPLY - VDE
 363215-01 USER MANUAL - DANISH
 312568-01 EXPANSION PORT GROUND CLIP
 251006-05 ANTI-STATIC BAG

312642-13 PACKING ASSY A590 HDD (NORWAY)

312643-01 MAIN ASSY A590 SCSI
 312643-02 MAIN ASSY SUB: 312643-01
 363143-01 INDIVIDUAL PACKING BOX (EFIGS)
 318202-01 TOP FOAM
 318203-01 BOTTOM FOAM
 312639-03 POWER SUPPLY - VDE
 363215-01 USER MANUAL - NORWEGIAN
 312568-01 EXPANSION PORT GROUND CLIP
 251006-05 ANTI-STATIC BAG

A590 HDD MAIN ASSEMBLIES (312643)

- 312643-01 MAIN ASSY A590 SCSI HARD DISK (EPSON)
 - 1 312647-01 TOP COVER ASSY
 - 3 312644-01 HARD DISK DRIVE ASSY EPSON 20MB
 - 5 312875-01 PCB & CONNECTOR PANEL ASSY (W/ EPSON)
 - 7 312621-01 INSULATION SHEET
 - 9 312622-01 BASE
 - 11 312623-01 NAMEPLATE A590 SCSI HD
 - 13 312636-02 RATING LABEL (MADE IN HK)
 - 15 312636-01 RATING LABEL (MADE IN US) SUB: 312636-02
 - 17 380133-03 LOGO
 - 19 906800-07 SCREW, METRIC, M3 X 5.0 LONG (QTY 4)
 - 21 906883-01 SCREW CROSS RECESSED M3 X 8 (QTY 4)
 - 23 906800-02 SCREW METRIC M3 X 10.0 LONG (QTY 2)
 - 25 312577-01 FOOT LABEL (QTY 2)
 - 27 316661-01 HARD DISK INFORMATION LABEL EPSON 20MB
 - 29 317734-01 CONTROLLER DISK ASSY (EPSON)
-

- 312643-02 MAIN ASSY A590 SCSI HARD DISK (WESTERN DIGITAL)
- 312647-01 TOP COVER ASSY
- 312644-02 HARD DRIVE ASSY WESTERN DIGITAL
- 312875-02 PCB & CONNECTOR PANEL ASSY (W/ WESTERN DIGITAL)
- 312621-01 INSULATION SHEET
- 312622-01 BASE
- 312623-01 NAMEPLATE A590 SCSI HD
- 312636-02 RATING LABEL (MADE IN HK)
- 312636-01 RATING LABEL (MADE IN US) SUB: 312636-02
- 380133-03 LOGO
- 906800-07 SCREW, METRIC, M3 X 5.0 LONG (QTY 4)
- 906883-01 SCREW CROSS RECESSED M3 X 8 (QTY 4)
- 906800-02 SCREW METRIC M3 X 10.0 LONG (QTY 2)
- 312577-01 FOOT LABEL (QTY 2)
- 316661-02 HARD DISK INFORMATION LABEL WESTERN DIGITAL
- 317734-02 CONTROLLER DISK ASSY (WESTERN DIGITAL)

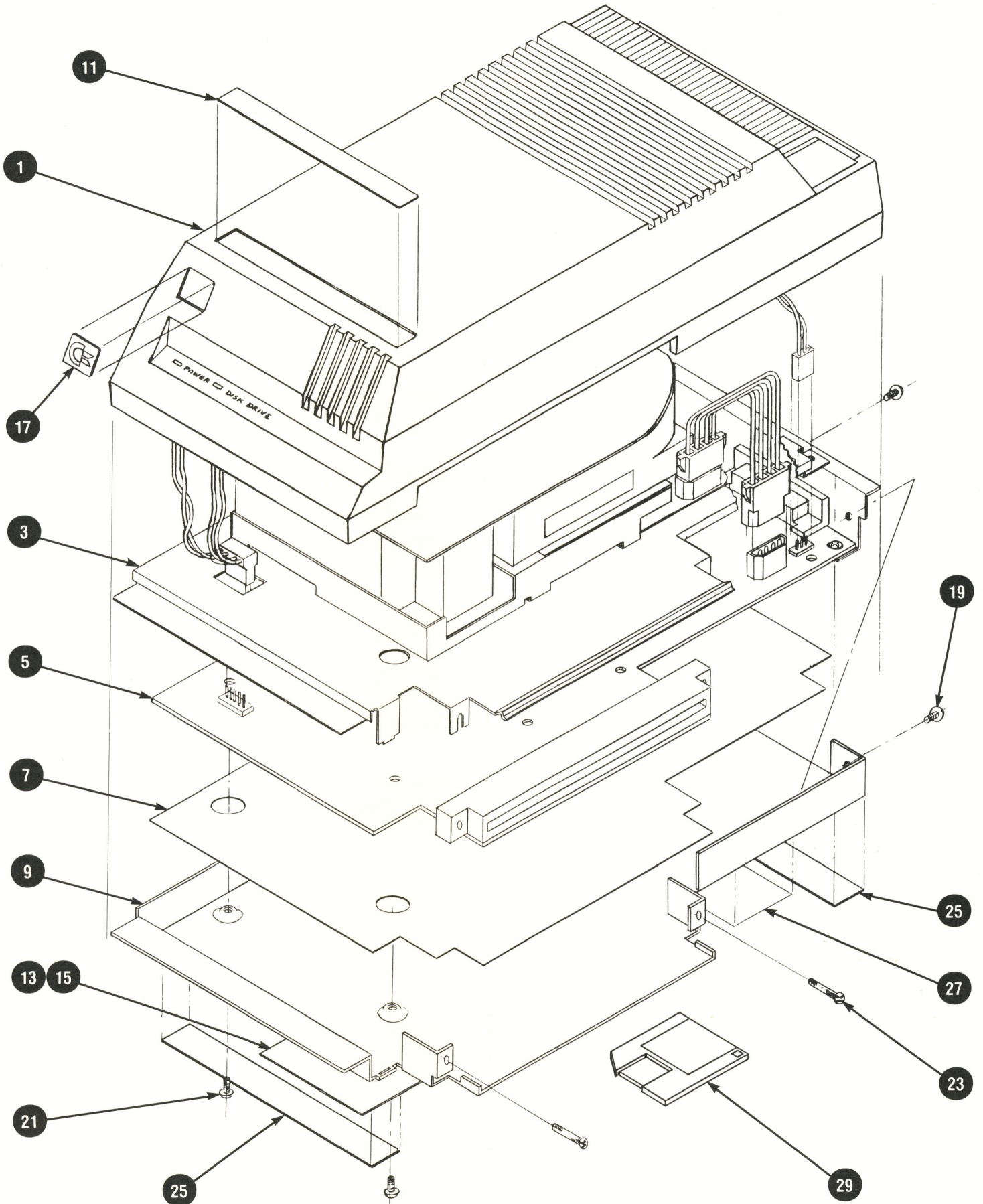

A590 HDD ASSEMBLIES (312644)

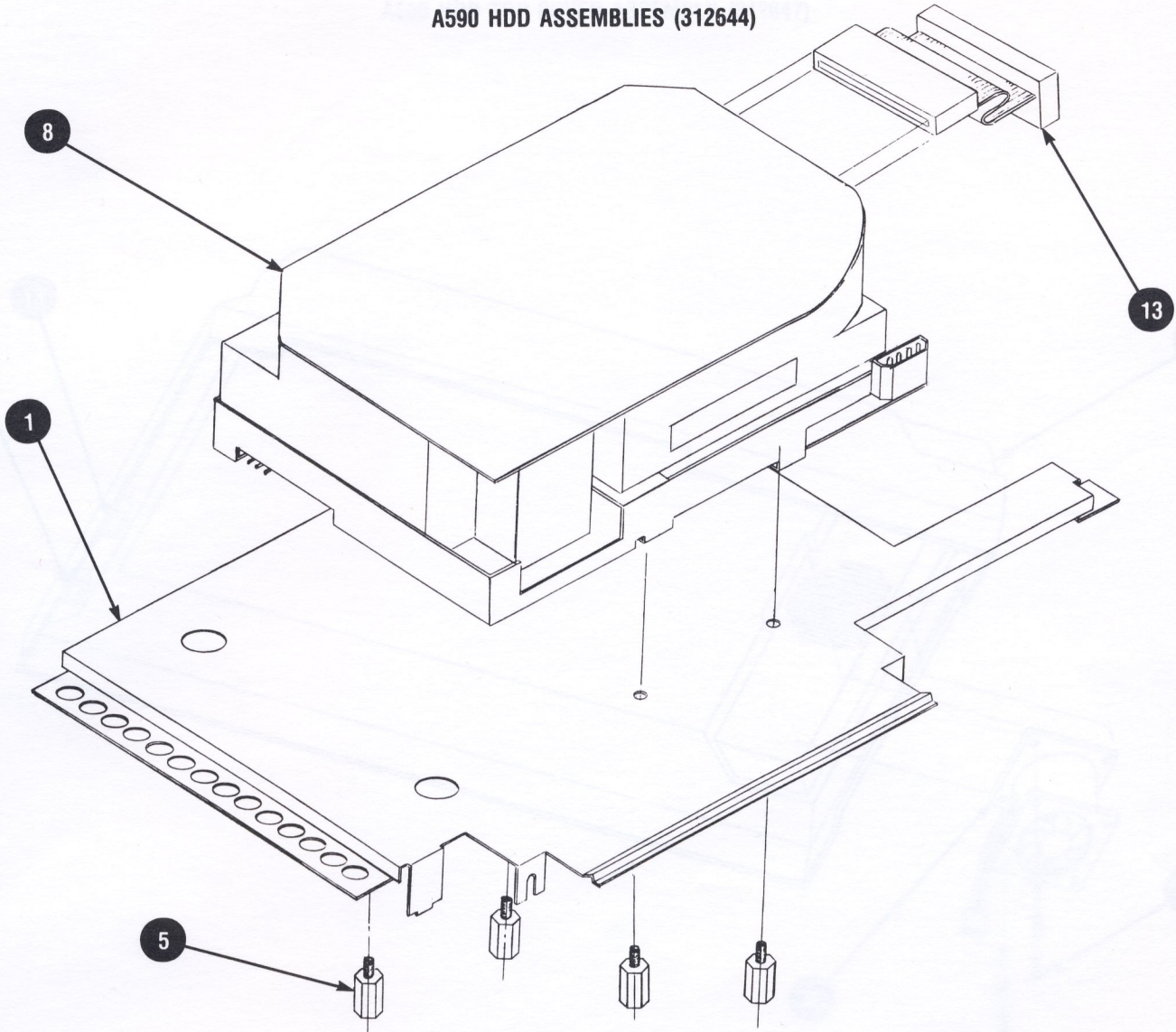

- 312644-01 HARD DISK DRIVE ASSY A590 (EPSON)
 - 1 312620-01 SHIELD
 - 5 390460-01 STANDOFF M3 M/FM (QTY 4) (EPSON)
 - 8 312711-01 3.5 HARD DISK DRIVE ASSY EPSON 20MB, SCSI
 - 13 312572-01 HARNESS ASSY DISK DATA 40 PIN
-
- 312644-02 HARD DISK DRIVE ASSY A590 (WESTERN DIGITAL)
 - 312620-01 SHIELD
 - 390459-01 STANDOFF 6/32 MALE M3 FEMALE (QTY 4)
 - 312711-02 3.5 HARD DISK DRIVE ASSY WESTERN DIGITAL
 - 312572-01 HARNESS ASSY DISK DATA 40 PIN

A590 HDD TOP COVER ASSEMBLY (312647)

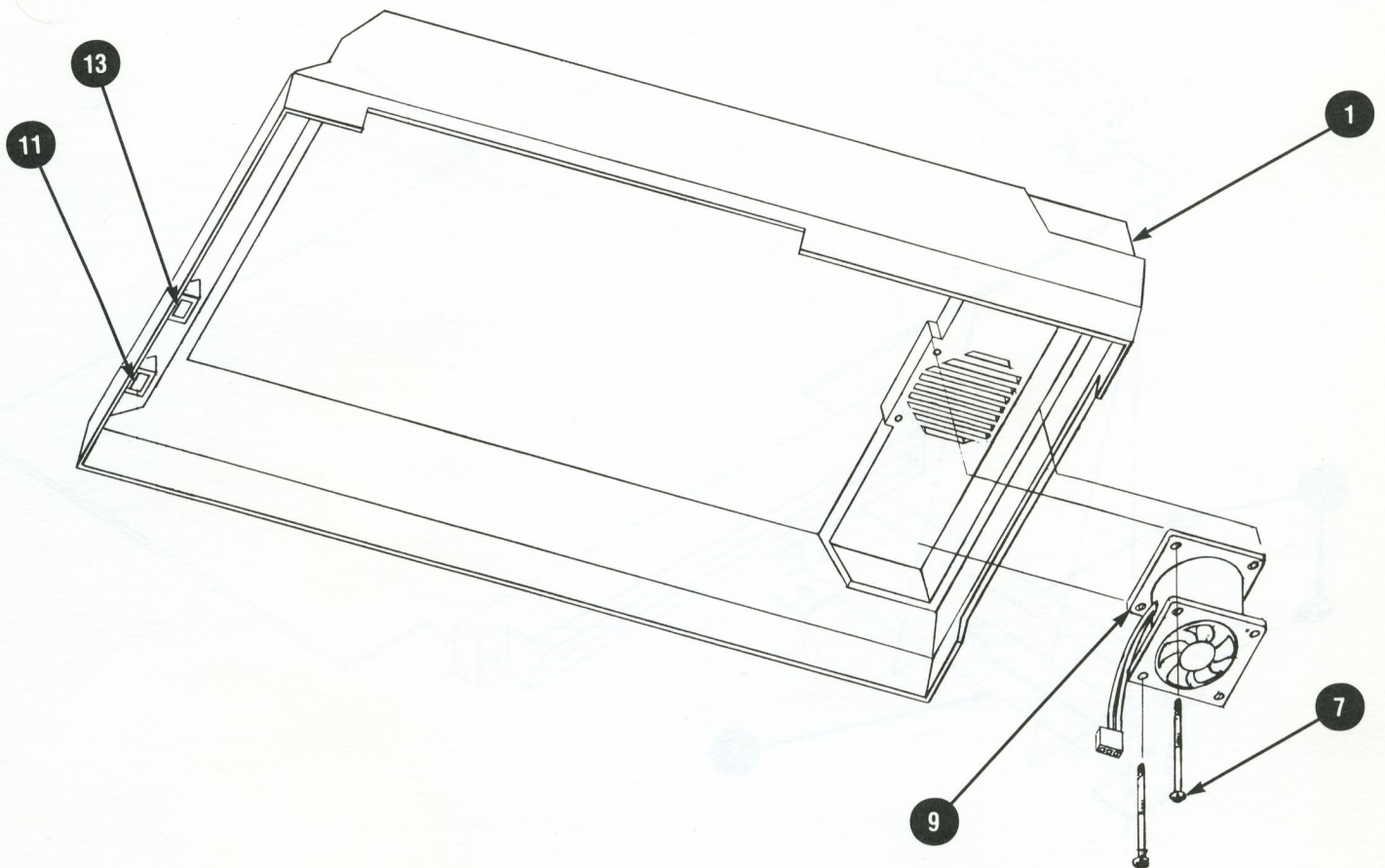

312647-01 TOP COVER ASSY, A590 SCSI / DISK DRIVE

- 1 312648-01 TOP COVER
- 7 906883-17 SCREW, SELF - TAPPING, M3 X 35 MM LG.
- 9 312611-01 FAN ASSY, A590 SCSI
- 11 312160-02 LED LENS GREEN
- 13 312160-03 LED LENS YELLOW

A590 PCB & CONNECTOR PANEL ASSY (312875)

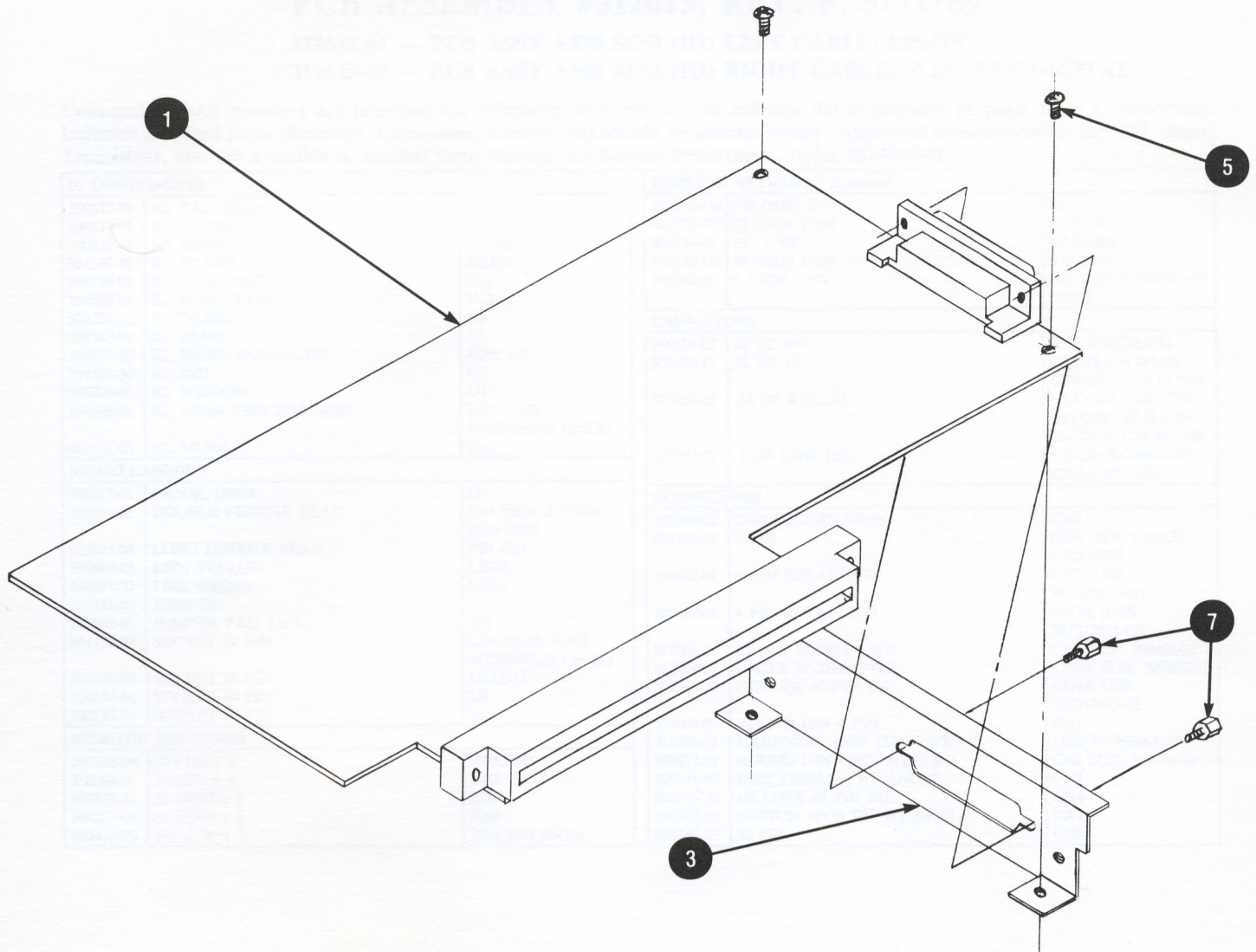

312875-01 PCB & CONNECTOR PANEL ASSY (LEFT DATA)

- 1 312615-01 PCB ASSY (EPSON)
- 3 312649-01 BASE CONNECTOR PANEL
- 5 906800-07 SCREW, METRIC, M3 X 5.0 LG. (QTY 2)
- 7 390251-01 STANDOFF HEX MALE/FEMALE 5MM

312875-02 PCB & CONNECTOR PANEL ASSY (RIGHT DATA)

- 312615-02 PCB ASSY (WESTERN DIGITAL)
- 312649-01 BASE CONNECTOR PANEL
- 906800-07 SCREW, METRIC, M3 X 5.0 LG. (QTY 2)
- 390251-01 STANDOFF HEX MALE/FEMALE 5MM

COMPONENT PARTS LIST

PCB ASSEMBLY #312615, REV. F, 5/11/89

312615-01 — PCB ASSY A590 SCSI (HD LEFT CABLE) EPSON

312615-02 — PCB ASSY A590 SCSI (HD RIGHT CABLE) WESTERN DIGITAL

Commodore part numbers are provided for reference only and do not indicate the availability of parts from Commodore. Industry standard parts (Resistors, Capacitors, Connectors) should be secured locally. Approved cross-references for TTL chips, Transistors, etc. are available in manual form through the Service Department, order #314000-01.

IC COMPONENTS			RESISTOR NETWORKS (continued)		
390333-01	IC, PAL 16L8A	U5	901550-134	130 OHM 1/4W	R6
390617-01	IC, 74ALS32	U11	901550-105	33 OHM 1/4W	R1,R5,R11
390332-01	IC, 74F158A	U8,U9	901550-01	1K, 1/4W	R2,R4,R8,R31
901521-46	IC, 74LS245	U2,U3	901550-131	56 OHM 1/4W	R12,R101
390388-01	IC, ROM - ODD	U12	390186-01	0 OHM 1/4W	JP8 USE W/390563-02 ONLY
390389-01	IC, ROM - EVEN	U13	CAPACITORS		
901521-32	IC, 74LS86	U6	390188-03	22 UF 16V	SUB: C2,C33,C34
390563-01	IC, DMAC	U1	900101-17	22 UF 35V	C2,C33,C34 (MAX LENGTH < = 13 MM
390563-02	IC, DMAC ENHANCED	SUB: U1	900020-09	.33 UF RADIAL	C1,C3,C4,C6,C7,C10,C11,C13,C15-18,C20-22,C24-26,C28-30,C401
901522-30	IC, 7407	U7	390397-01	.1 UF LOW ESR	C5,C8,C9,C100,C101,C202,C207,C208
390206-01	IC, WD33C93	U4	CONNECTORS		
390398-01	IC, 16R4A PROGRAMMED	U101 (USE W/390563-01 ONLY)	310366-02	CARD EDGE, 86PIN	CN2
901521-03	IC, 74LS08	U10	903332-03	3 PIN	CN8, JP3 .1 INCH CENTERS
MISCELLANEOUS			390462-01	4 PIN POLARIZED	CN7 (USE W/312615-01)
390017-01	DIODE, IN914	D1	390462-01	4 PIN POLARIZED	CN7A (USE W/312615-02)
252214-01	DOUBLE FERRITE BEAD	FB4-FB20 .2 INCH SPACING	312004-01	CABLE W/DRV PWR	CN7 SUB: 390462-01
903025-08	LONG FERRITE BEAD	FB1-FB3	312004-01	CABLE W/DRV PWR	CN7A SUB: 390462-01
390386-03	LED, YELLOW	LED2	903345-20	HEADER 40 PIN DIL	CN4A USE W/312615-02
390387-02	LED, GREEN	LED1	359004-01	ROUND DIN 4 PIN	CN1
380333-01	JUMPER	JP1	312789-01	HARDNESS ASSY DRV PWR	USE W/390462-01
390362-01	JUMPER PAD 2 x 4	U5,U14-28, (U101 W/390563-01 ONLY)	390272-01	ROUND DIN 4 PIN SHIELED	CN1 SUB: 359004-01
904150-08	SOCKET 20 PIN	U12,U13	390241-05	DB25 FEMALE, RT ANGLE	CN5
904150-05	SOCKET 28 PIN	U4	903345-20	HEADER 40 PIN DIL	CN4
904150-06	SOCKET 40 PIN	U1	390363-01	SWITCH 4POS DIP RT ANGLE	SW1
390185-01	SOCKET 84 PIN		903345-25	50 PIN	CN6
RESISTOR NETWORKS					
380388-04	220/330 x 8	RN1,RN3			
380388-01	220/330 x 4	RN2			
902422-03	33 OHM x 4	RN7			
390227-04	33 OHM x 5	RN8			
902410-08	SIP 4.7K x 9	RN4,RN5,RN201			

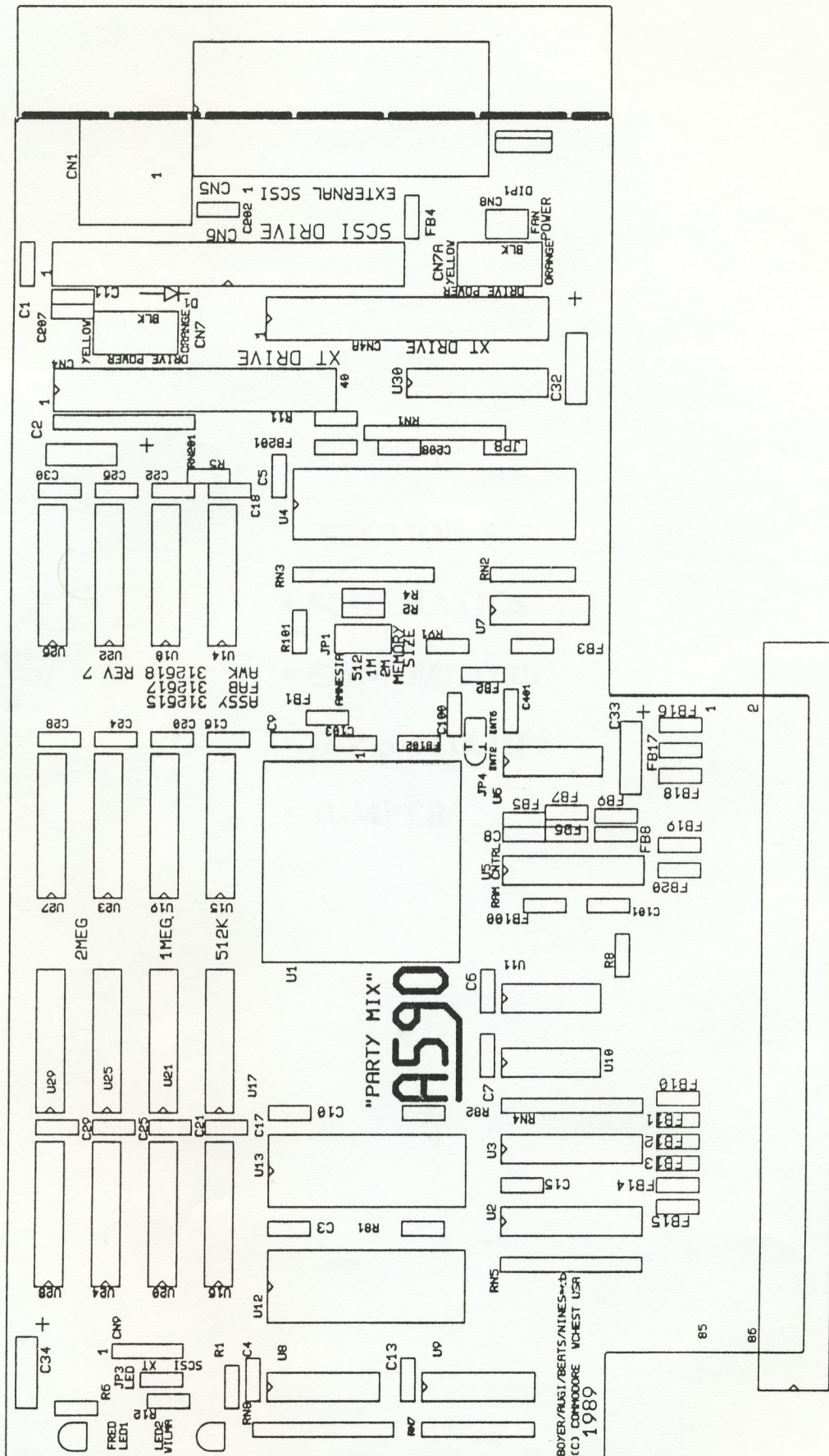

A590 BOARD LAYOUT #312615

SECTION 5

- **SCHEMATICS**
- **CONNECTORS**
- **DIP SWITCHES**
- **JUMPERS**

DMAC

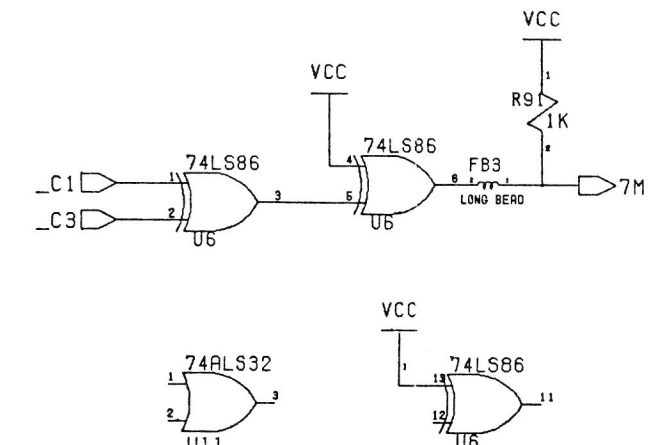
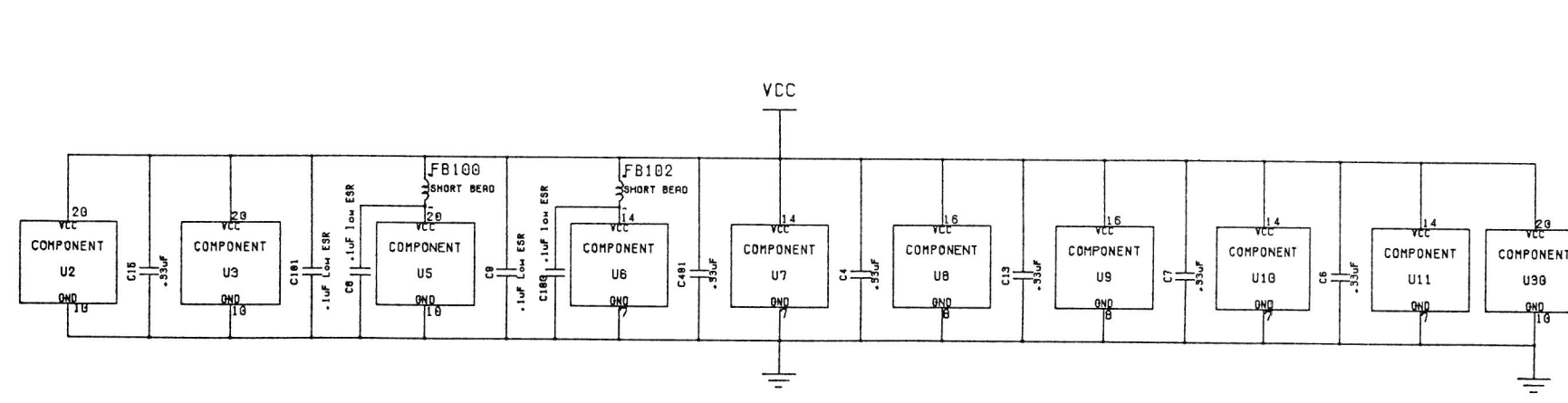
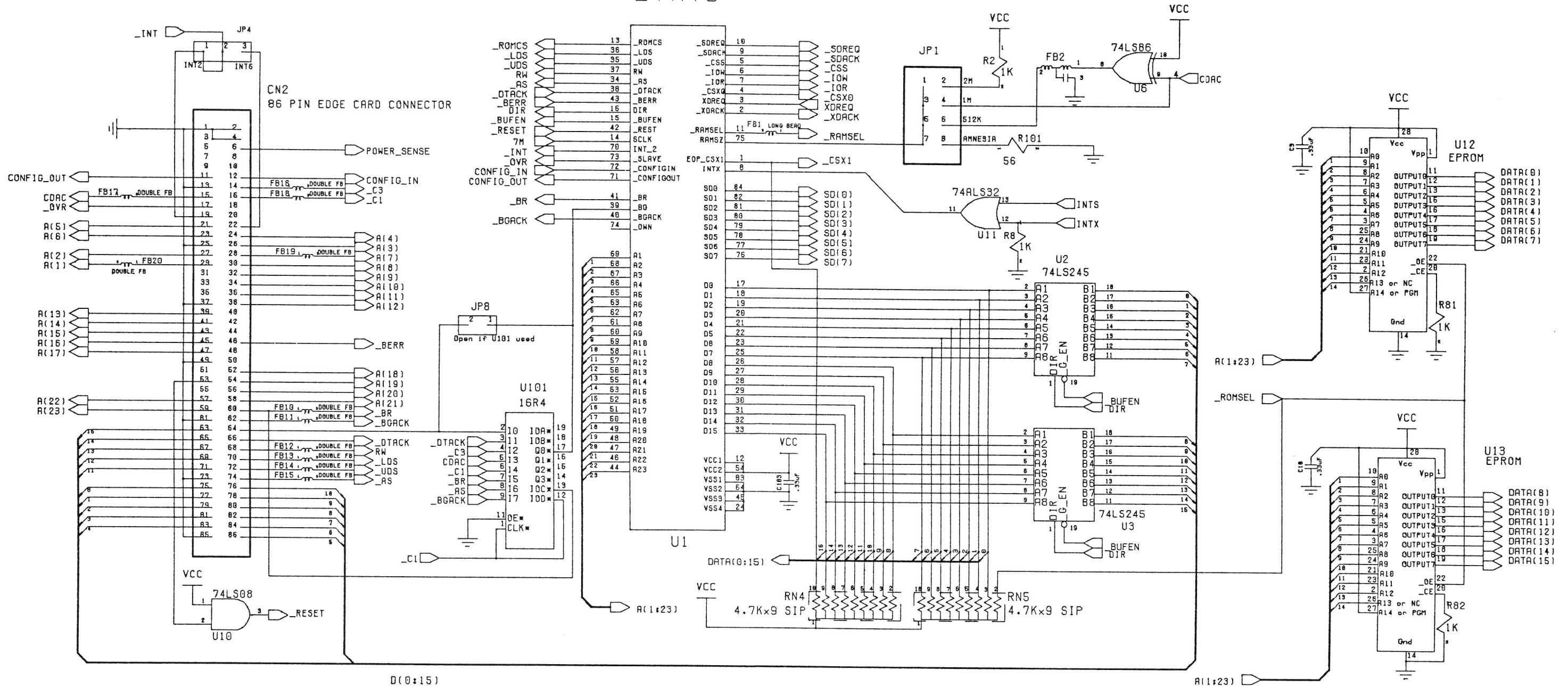

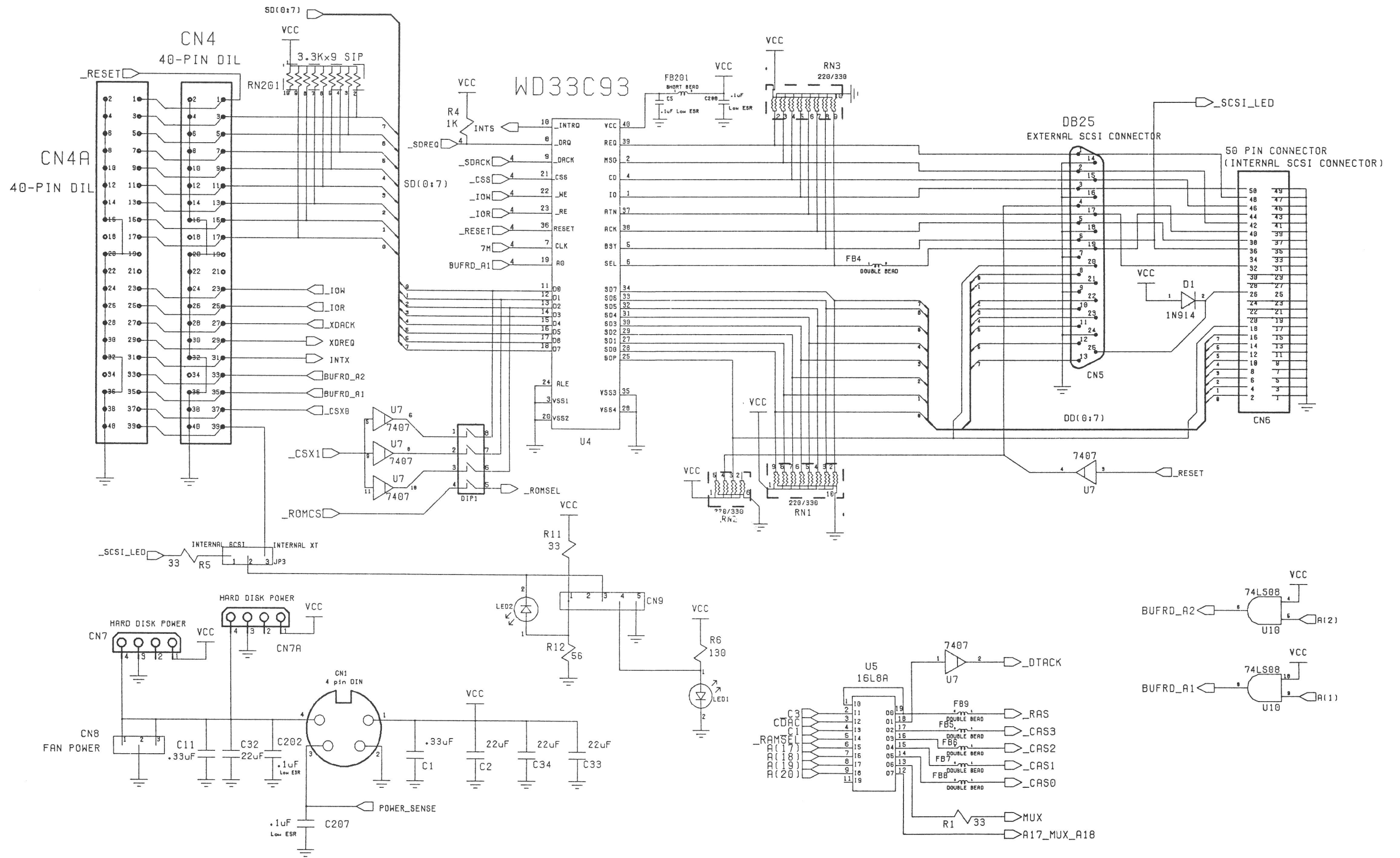

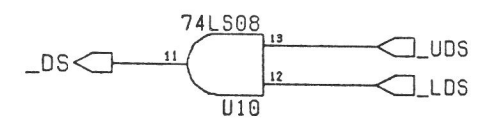
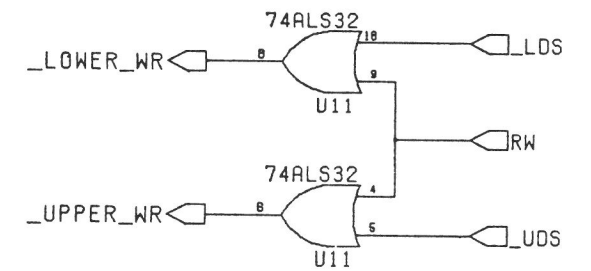
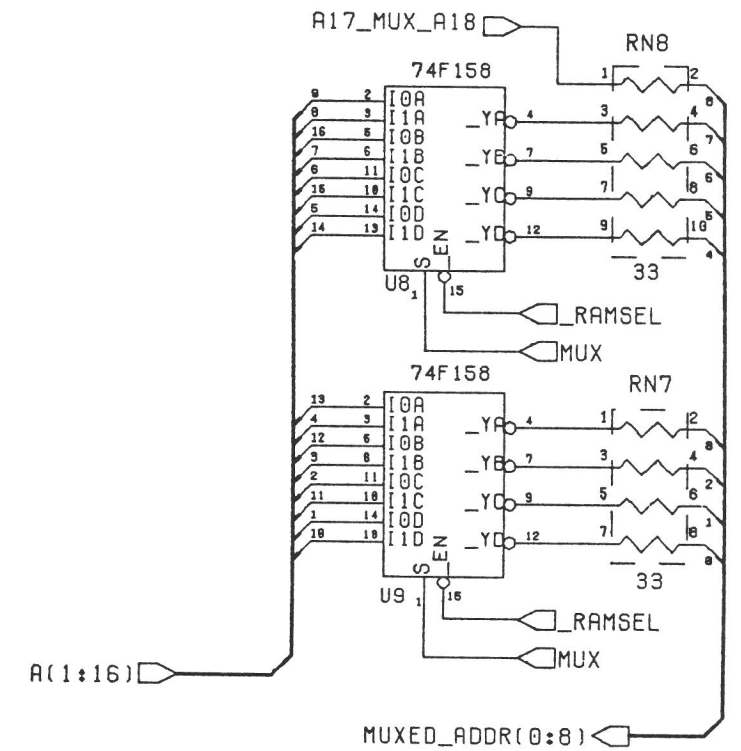
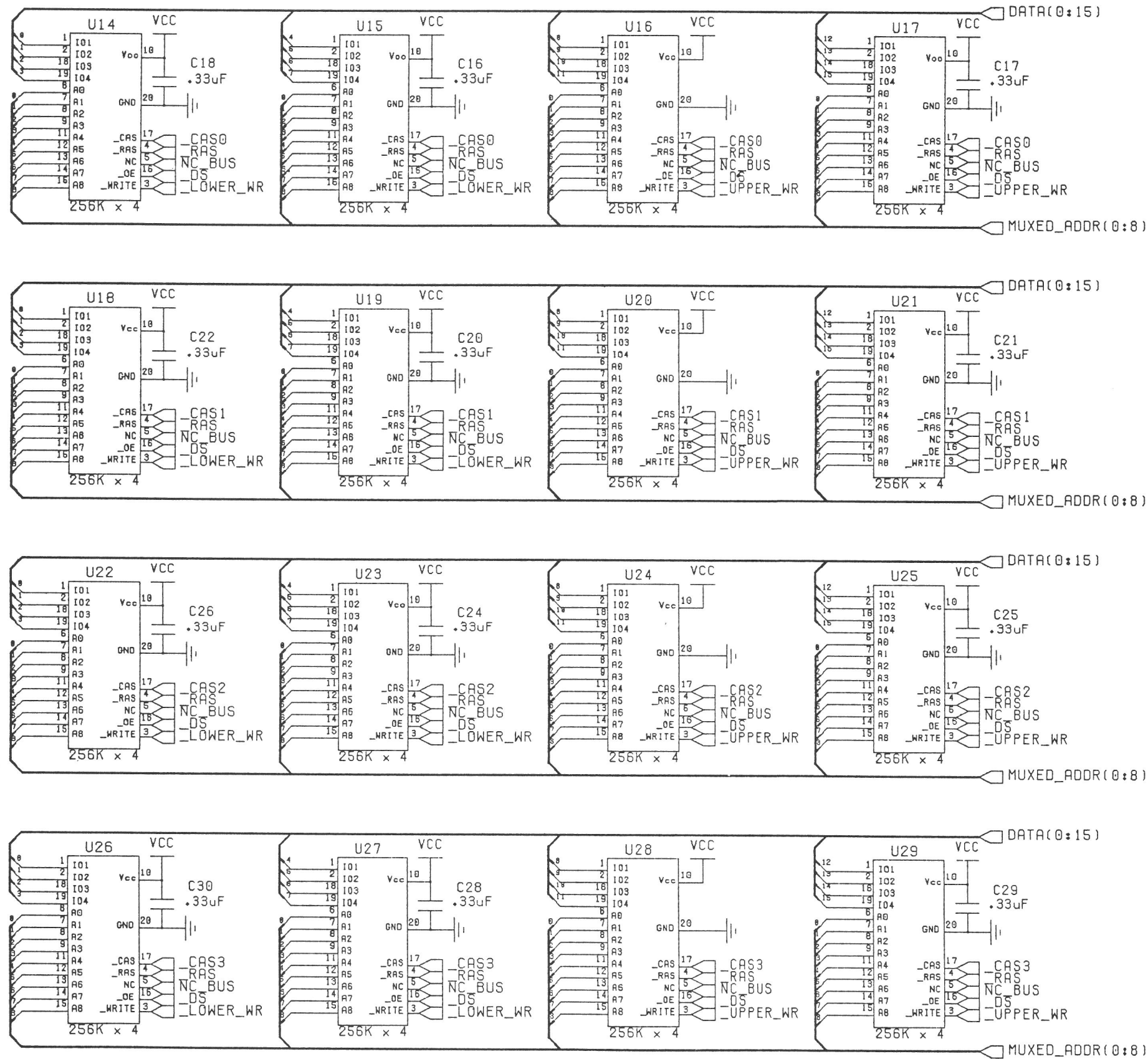

NOTE: NO CONNECT ON DRAM'S ARE CONNECTED TOGETHER TO FACILITATE FUTURE CONVERSION TO 4M PART (1M X 4)

Internal SCSI Connector

Pin	Name		
● 50	● 49	50	I/O
● 48	● 47	48	REQ
● 46	● 45	46	C/D
● 44	● 43	44	SEL
● 42	● 41	42	MSG
● 40	● 39	40	RST
● 38	● 37	38	ACK
● 36	● 35	36	BSY
● 34	● 33	34	N.C.
● 32	● 31	32	ATN
● 30	● 29	30	Ground
● 28	● 27	28	Ground
● 26	● 25	26	Termination Power
● 24	● 23	24	Ground
● 22	● 21	22	Ground
● 20	● 19	20	Ground
● 18	● 17	18	Parity
● 16	● 15	16	Data 7
● 14	● 13	14	Data 6
● 12	● 11	12	Data 5
● 10	● 9	10	Data 4
● 8	● 7	8	Data 3
● 6	● 5	6	Data 2
● 4	● 3	4	Data 1
● 2	● 1	2	Data 0

All odd pins, except pin 25, are ground. Pin 25 is open.

Internal XT Connector

Pin	Name		
● 40	● 39	39	Not used
● 38	● 37	37	Select
● 36	● 35	35	Addr 1
● 34	● 33	33	Addr 0
● 32	● 31	31	Int
● 30	● 29	29	Data-Req
● 28	● 27	27	Data-Ack
● 26	● 25	25	IORead
● 24	● 23	23	IOWrite
● 22	● 21	21	Not used
● 20	● 19	19	Ground
● 18	● 17	17	Data 0
● 16	● 15	15	Data 1
● 14	● 13	13	Data 2
● 12	● 11	11	Data 3
● 10	● 9	9	Data 4
● 8	● 7	7	Data 5
● 6	● 5	5	Data 6
● 4	● 3	3	Data 7
● 2	● 1	1	Reset

Pins 18 and 34 are not used.
All other even pins are ground.

External SCSI Connector (DB-25)

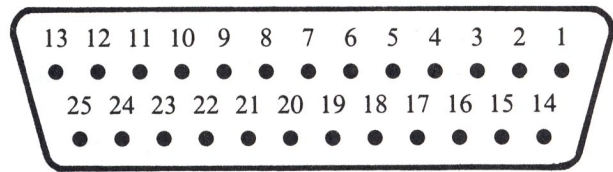

Female Connector

Pin	Name	Pin	Name
1	REQ	14	Ground
2	MSG	15	C/D
3	I/O	16	Ground
4	RST	17	ATN
5	ACK	18	Ground
6	BSY	19	SEL
7	Ground	20	Parity
8	Data 0	21	Data 1
9	Ground	22	Data 2
10	Data 3	23	Data 4
11	Data 5	24	Ground
12	Data 6	25	Termination Power
13	Data 7		

Hard Disk Power Connector

- .85 A Maximum Continuous Current at 12V
- 2.6 A Maximum Startup Current at 12V
- 1.0 A Maximum Continuous Current at 5V

- 1. +5 VDC
- 2. ground
- 3. ground
- 4. +12 VDC

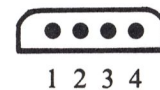

Fan Connector

- 1. +12 VDC
- 2. ground
- 3. +12 VDC

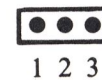

4 Pin Power Connector

- 1. +5 VDC
- 2. ground
- 3. power sense
- 4. +12 VDC

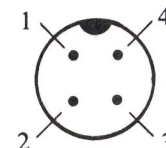

DIP Switch Settings

Switch 1 off	Disables Autoboot ROMs	Kickstart 1.2
on	Enables Autoboot ROMs	Kickstart 1.3
Switch 2 off	LUN disabled	One drive at each address.
on	LUN enabled	Multiple drives at each address.
Switch 3 off	Time-out disabled	Short wait period for drive. Parity checking enabled.
on	Time-out enabled	Long wait period for drive. Parity checking disabled on message-in phase.
Switch 4	Reserved for future enhancements.	

Note: Parity checking is not supported on some Seagate drives. With these drives set the switch to the on position.

Switch 1: Autoboot Enable If you are using Kickstart 1.3, you can set Switch 1 to the **on** position. This will allow you to boot your system from the A590.

Switch 2: LUN Enable This switch only affects SCSI drives. If you have more than one device at a physical address, set Switch 2 to **on**. When this switch is in the **off** position, the system only looks for one Logical Unit Number (LUN), or one drive, at each physical SCSI address. When this switch is in the on position the system will attempt to open Logical Units 0 through 7 at each physical SCSI address.

Note: Some SCSI drives such as certain Seagate™ and Epson™ drives, respond to more than one logical address. Such drives will appear on the Workbench screen and the **Hard Drive Preparation, Partitioning and Formatting** screen in **HDTtoolbox** multiple times, at the same Address but at LUN 0 through 7. If this occurs, set switch 2 to **off**.

Switch 3: Time-out Length If you are using a SCSI drive that takes longer than thirty seconds to start up when you turn the system on, such as some Seagate drives, you may wish to set Switch 3 to **on**. When the switch is on the **off** position the time-out period, (the time between the start-up and when the system checks the drive), is short. When the switch is in the on position the system will wait a longer time before checking the drive.

Switch 4: Reserved.

Jumper Settings

Note: The A590 is shipped with all jumpers set to 1.

JUMPER	SETTING	NOTES
JP1	1. Amnesia 2. 512K 3. 1MB 4. 2MB	RAM memory installed on the A590 board.
JP3	1. XT drive 2. SCSI drive	Sets LED for XT or SCSI drive.
JP4	1. Interrupt 2 2. Interrupt 6	Interrupt level. Not user adjustable.



Computer Systems Division
1200 Wilson Drive
West Chester, PA 19380