

APPLICATION		REVISION			
NEXTASSEMBLY	USED ON	LTR	DESCRIPTION	DATE	APPROVED
	C65	A	SPECIFICATION RELEASE	1-31-91	<i>J. Young</i>

1.0 DESCRIPTION

This specification describes the requirements for a power supply used in a microcomputer system. The power supply shall be a stand-alone device housed in its own enclosure. It shall provide outputs of +5VDC and +12VDC with maximum currents of 2.2 and 0.5 amperes respectively. The device shall have a fused input circuit.

- 313375-01 = 120 VAC unit (UL/CSA) (United States and Canada)
- 313375-02 = 240 VAC unit (BSI) (British Isles)
- 313375-03 = 220 VAC unit (VDE) (W. Germany)
- 313375-04 = 240 VAC unit (SEV) (Switzerland)
- 313375-05 = 240 VAC unit (SAA) (Australia)

Notes: 1. The 313375-01 unit shall meet FCC Class B requirements plus UL 1012 and CSA requirements. Vendor shall assist

in obtaining system approval if requested.

2. The 313375-02,-03, -04 and -05 units shall meet IEC 380 Class 1 and FTZ Class B requirements. Vendor shall assist in obtaining system approval if requested.

1.1 CONFIGURATON

Refer to Figure 1-1 for external dimensions.

Refer to Figure 1-2 for power supply connector.

1.2 SOURCES

Refer to Approved Vendor List.

Commodore P/N	Status	Commodore P/N	Status
313375-01	Active	313375-05	Active
313375-02	Active		
313375-03	Active		
313375-04	Active		

UNLESS OTHERWISE SPECIFIED DIMENSIONS ARE IN INCHES.

TOLERANCES:

ANGLES +/- 1 DEGREE

2 PLACE DECIMALS +/- 0.02

3 PLACE DECIMALS +/- 0.010

DRAWN
A. Young
SYSTEM ENGR.
(Signature)
TEST ENGR.

DATE
DATE
DATE
1/24/91

Commodore
1200 WILSON DRIVE
WEST CHESTER, PA 19380
(215) 431-9100

COPYRIGHT 1991
COMMODORE ELECTRONICS LTD.
INFORMATION CONTAINED HEREIN IS THE UNPUBLISHED AND CONFIDENTIAL PROPERTY OF COMMODORE ELECTRONICS LIMITED. USE, REPRODUCTION OR DISCLOSURE OF THIS INFORMATION WITHOUT THE PRIOR WRITTEN PERMISSION OF COMMODORE IS STRICTLY PROHIBITED. ALL RIGHTS RESERVED.

COMP. ENGR.
D. Shannon *(Signature)*
CIRCUIT ENGR.
PROD. ASSUR.

DATE
DATE
DATE
24 JAN 91

TITLE:
POWER SUPPLY,
EXTERNAL, C65
SIZE
A
DRAWING NUMBER
313375
SCALE
SHEET 1 of 6

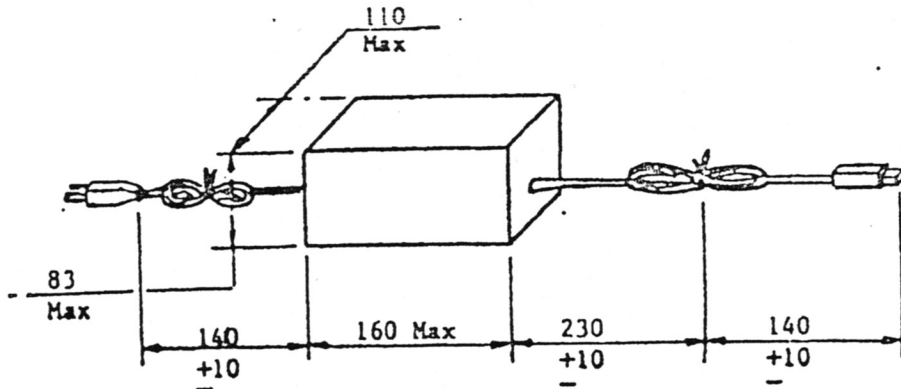

Note: dimensions are in millimeters.

FIGURE 1-1
External Dimensions

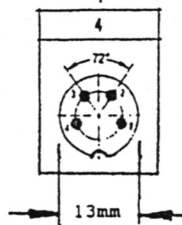
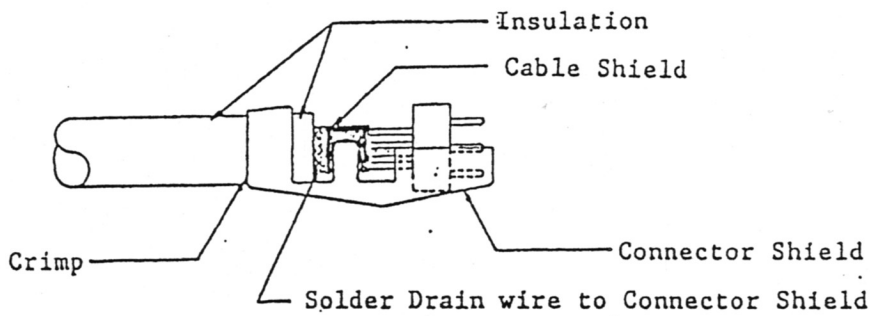

LEGEND:
 Pin 1: +5 VDC
 Pin 2: GROUND
 Pin 3: NC
 Pin 4: +12 VDC

FIGURE 1-2
Power Supply Connector

Commodore

TITLE:
POWER SUPPLY,
EXTERNAL, C65

SIZE
A

DRAWING NUMBER
313375

REV.
A

SCALE

SHEET 2 OF 6

2.0 ELECTRICAL CHARACTERISTICS

2.1	AC Input Voltage:	105 to 132 VAC (-01) 198 to 242 VAC (-02) 216 to 264 VAC (-03, -04, -05)
2.2	AC Input Frequency:	57 to 63 Hz (-01) 47 to 53 Hz (-02, -03, -04, -05))
2.3	DC Output Voltage : (at output connector)	+ 5.0 VDC +/- 5% (10% to 100% load) + 12.0 VDC +/- 10% (0 to 100% load)
2.4	Output Current:	2.2 amperes max. (+5.0 VDC) 0.5 amperes max. (+ 12.0 VDC)
2.5	Maximum Continuous Power Output	Any combination within the following range is allowed: + 5 VDC: 10 to 100% rated load +12 VDC: 0 to 100% rated load
2.6	Nominal Loading:	50% of max. rated output current
2.7	Minimum Loading:	+ 5VDC: 10% of rated output current + 12 VDC: 0% of rated output current
2.8	Line, Load, and Cross Regulation: (measured at output connector)	+5 VDC at 10 to 100% rated continuous load: +/-5% +12 VDC at 0 to 100% rated continuous load: +/-10 %
2.9	Ripple and Noise:	+5 VDC: 100 mV peak to peak max. +12 VDC: 200 mV peak to peak max. (steady state)
2.10	Overvoltage Protection:	+5 VDC: + 6.0 VDC min., + 7.0 VDC max.
2.11	Overcurrent Protection:	Unit shall tolerate a short circuit condition (≤ 0.1 ohm) on any or all outputs for an indefinite duration without damage and without exceeding case temperature limitations of regulatory agencies or 90 deg. C, whichever is lower
2.12	Input Surge Protection:	3KV, 25 amperes for 3 ms minimum (Varistor)
2.13	Surge Current (max.):	Same as continuous current (for +5 VDC and +12 VDC)
2.14	Surge Power Output (max.):	Startup total load power shall not exceed continuous rating
2.15	Surge Cross Regulation:	With 12 VDC supply at full rated surge load, 5 VDC supply shall continue to meet basic cross regulation requirements
2.16	Efficiency:	50% min. at nominal input, maximum loads
2.17	Hold-Up Time:	16.67 ms min. at minimum AC input, 100% load
2.18	Transient Response:	200 μ s max. for +5 VDC output to stabilize after 5% change on 50% load

Commodore

TITLE:

POWER SUPPLY,
EXTERNAL, C65

SIZE
A

DRAWING NUMBER
313375

REV.
A

SCALE

SHEET 3 OF 6

2.0 ELECTRICAL CHARACTERISTICS (continued)

- 2.19 Input Current Protection: Turn-on inrush current not to exceed 20 ampere
- 2.20 No Load Input Current: 0.1 ampere max. at 120VAC, 60 Hz
0.05 ampere max. at 220 or 240 VAC, 50 Hz
- 2.21 Dielectric Withstanding Voltage: 1000 VAC for one minute
- 2.22 Non-Seif-Destructing: Unit shall not self-destruct under ANY conditions.

NOTES ON ELECTRICAL CHARACTERISTICS

LINE REGULATION is defined as the maximum allowable deviation of an output voltage from its specified nominal value when the AC input is taken above or below its nominal value to the rated maximum or minimum level.

LOAD REGULATION is defined as the maximum allowable deviation of an output voltage from its specified nominal value when the load is taken above or below its nominal value to the rated maximum or minimum level.

CROSS REGULATION is defined as the effect seen in any auxiliary output when a change is made in the main +5 VDC output. The auxiliary output being measured shall be loaded to 20% of its maximum capacity and the main output shall be loaded to 60% of its maximin with a change of +/- 30%. The effect of one auxiliary output on another is measured in the same way: the measured output 20% loaded and the affecting output loaded 60% +/- 30%.

RIPPLE and NOISE are measured at maximum rated load. This combination peak to peak measurement of ripple and noise is made at the output connection.

Commodore

TITLE:
POWER SUPPLY,
EXTERNAL, C65

SIZE A	DRAWING NUMBER 313375	REV. A	SCALE	SHEET 4 OF 6
-----------	--------------------------	-----------	-------	--------------

3.0 PHYSICAL REQUIREMENTS

- 3.1 Cabinet Material: Impact resistant thermoplastic
- 3.2 Color (Enclosure: and Cables) Commodore Basic Light Beige (Munsell #2.0Y 7.58/1.4; Gloss 10 + 2 on 60 deg. gloss meter).
- 3.3 Markings: Unit shall be marked with Commodore eight (8) digit part number, EIA code, Commodore Logo, Commodore bar code per specification 310071, input voltage requirements, output voltages, maximum output power, and required regulatory approval logos.
- 3.5 AC Cable and Connector: AC cable and connector shall meet specifications in Commodore drawing 903508 (Power Cord International).

DC connector (4-pin DIN round plug with key) shall include shielding clamped and soldered to cable shield. (Refer to Figure 1-2 for detailed connector specifications and wire list.)
- 3.6 DC Cable and Connector Three 22 -gage (min.) conductors with copper braid (90% coverage) (See Figure 1-2), or foil shielding with drain wire soldered to connector shield.

Commodore

TITLE:

POWER SUPPLY,
EXTERNAL, C65

SIZE A	DRAWING NUMBER 313375	REV. A	SCALE	SHEET 5 OF 6
-----------	--------------------------	-----------	-------	--------------

4.0 ENVIRONMENTAL REQUIREMENTS

Units furnished to the requirements of this specification shall meet the following environmental resistance requirements (vendors shall furnish documentation upon request):

Operating Temperature:	0 to 50 deg. C
Operating Humidity:	5 to 95% RH non-condensing
Operating Altitude:	0 to 3000 meters
Storage Temperature:	- 20 to +70 deg. C
Storage Humidity:	5 to 95% RH non-condensing
Storage Altitude:	0 to 15,000 meters
Shock:	30 g's-11 msec-1/2 sine, two shocks in each of six directions

5.0 ENVIRONMENTAL TEST CONDITIONS

Devices shall comply with the following environmental resistance tests per Commodore Test Procedure 1.02.010:

Operating life (1000 hours at 50 deg. C)

Case temperature rise (10 deg. C above ambient during normal operation)

Note: Units shall meet this specification's operating performance requirements after the above tests are completed.

6.0 RELIABILITY

Mean Time Between Failures shall be 50,000 hours min. at 35 deg. C, nominal input, 75% load all outputs.

7.0 ENGINEERING CHANGES

No changes shall be made to the devices specified herein, which affect its form, fit, or function, without prior approval from Commodore Engineering.

Commodore

TITLE:
POWER SUPPLY,
EXTERNAL, C65

SIZE
A

DRAWING NUMBER
313375

REV.
A

SCALE

SHEET 6 OF 6

APPROVED VENDOR LIST

THIS SHEET MUST BE REMOVED FROM THIS DOCUMENT
BEFORE THE DOCUMENT IS SHOWN OR TRANSMITTED TO A VENDOR.

Commodore P/N	Vendor	Vendor P/N
313375-01	SPEEDY TECH	STP-689
313375-02	SPEEDY TECH	TBD
313375-03	SPEEDY TECH	TBD
313375-04	SPEEDY TECH	TBD
313375-05	SPEEDY TECH	TBD

Commodore

TITLE:
POWER SUPPLY,
EXTERNAL, C65

SIZE
A

DRAWING NUMBER
313375

REV.
A

SCALE

SHEET i of i